

~~4160~~
4160

CONTROL DATA[®] 9465 DISK STORAGE DRIVE

P12 AND ABOVE

MAINTENANCE

CONTROL DATA
CORPORATION

CUSTOMER ENGINEERING MANUAL

**CONTROL DATA® 9465
DISK STORAGE DRIVE**

P12 AND ABOVE

MAINTENANCE

CONTROL DATA
CORPORATION

CUSTOMER ENGINEERING MANUAL

Carriage Assembly or Detent Shaft Replacement	6-15	Home Cell Mechanical Adjustment	6-51
Timing Disk/Detent Gear Assembly Replacement	6-21	Track/Speed Photocell Mechanical Adjustment	6-52
Access Motor Replacement	6-22	Track Photocell Rotational Adjustment	6-54
Detent Pawl Replacement	6-24	Carriage Limit Stop Adjustment	6-55
Detent Magnet Replacement	6-25	Head Latch Solenoid and Switch Adjustment	6-56
Head Latch Solenoid or Micro-switch Replacement	6-25	Cam Latch Solenoid Adjustment	6-57
Cam Latch Solenoid Replacement	6-26	Cover interlock Switches Adjustment	6-59
Head/Arm Replacement	6-27	Actuator Dynamic Tests and Adjustments	6-60
Torsion Arm/Shaft Replacement	6-29	Read Operation Test and Adjustment	6-68
Adjustment	6-35	Delay Tests and Adjustments	6-73
Spindle Lock Adjustment	6-35	Power Level Adjustment	6-75
Pack-On Switch Adjustment	6-35	Power Supply Troubleshooting	6-77
Drive Belt Tension Adjustment	6-36		
Brush Arm and Linkage Adjustment	6-36		
Fiber Optic Adjustment	6-37		
Detent Adjustment	6-39		
Head/Arm Adjustment	6-41		
Actuator Adjustment	6-43		
Sector/Presector Block Tangential and Radial Adjustment	6-47		
		7. SPECIAL MAINTENANCE INFORMATION	
		Installation Requirements and Procedures	7-1
		Initial Checkout Procedure	7-1
		Disk Pack Runout Check	7-4

FIGURES

2-1	Disk Pack Load and Unload Mechanics	3-2	Power Supply	3-9	
2-2	Operator Panel	2-3	3-3	Power Supply General Block Diagram	3-10
2-3	Logic Chassis Maintenance Panel	2-4	3-4	Logic Chassis, Front View	3-11
2-4	Power Supply Control Panel	2-5	3-5	Logic Chassis, Rear View	3-12
3-1	General Block Diagram	2-5	3-6	Spindle Cone	3-13
		3-1	3-7	Spindle and Brake Assembly	3-14
			3-8	Sector Disk	3-16
			3-9	Actuator Assembly	3-18

3-10	Carriage Subassembly	3-19	6-11	Sector/Presector Pulse Timing	6-49	
3-11	Head/Arm Assembly	3-20	6-12	Photocell/Amplifier Outputs	6-53	
3-12	Elements of Carriage Mount Subassembly	3-21	6-13	Carriage Limit Stop Adjustment	6-56	
3-13	Carriage Drive and Positioning Mechanism	3-23	6-14	Head Latch Solenoid Adjustment	6-57	
3-14	Actuator Cutaway-Front View	3-24	6-15	Cam Latch Solenoid Adjustment	6-58	
3-15	Timing Disk	3-25	6-16	Tachometer Output (3-Track Forward Seek)	6-62	
3-16	Head Loading Components	3-27	6-17	Tachometer Output (Forward Seek)	6-63	
3-17	Head Loading Mechanism	3-29	6-18	Tachometer Output (Reverse Seek)	6-64	
3-18	Cabinet Cooling	3-31	6-19	Dynamic Track Photocell Adjustment	6-66	
3-19	Cylinder Concept	3-32	6-20	Tachometer Output (Various Seek Lengths)	6-69	
4-1	System Intercabling Diagram (Daisy Chain)	4-1	6-21	Pulse Shaper Trace	6-70	
4-2	System Power-On Sequencing Circuit	4-2	6-22	Read/Write Peak Shift	6-71	
			6-23	Read/Write Amplitude (Track 00)	6-72	
6-1	Lock and Belt Adjustment	6-4	6-24	Read/Write Amplitude (Track 202)	6-72	
6-2	Pack-On Switch Adjustment	6-5	6-25	On Cylinder Delay Timing	6-74	
6-3	Brush Assembly	6-9	6-26	Head Select Timing	6-75	
6-4	Brush Linkage Adjustment	6-10	7-1	Outline Dimensions	7-2	
6-5	Fiber Optic Source Lamp	6-12	7-2	Intracabling of Disk Storage Drive	7-3	
6-6	Detent Subassembly	6-15	6-48	7-3	Disk Pack Runout Gage	7-5
6-7	Head/Arm Assembly Adjustment	6-28				
6-8	Head/Arm Adjustment	6-45				
6-9	Index to Data Period	6-46				
6-10	Sector/Presector Radial Adjustment	6-48				

TABLES

1-1	Input/Output Connector Pin Assignments	3-1	Input/Output Lines	3-2
1-6		6-1	Power Supply Troubleshooting Chart	6-78

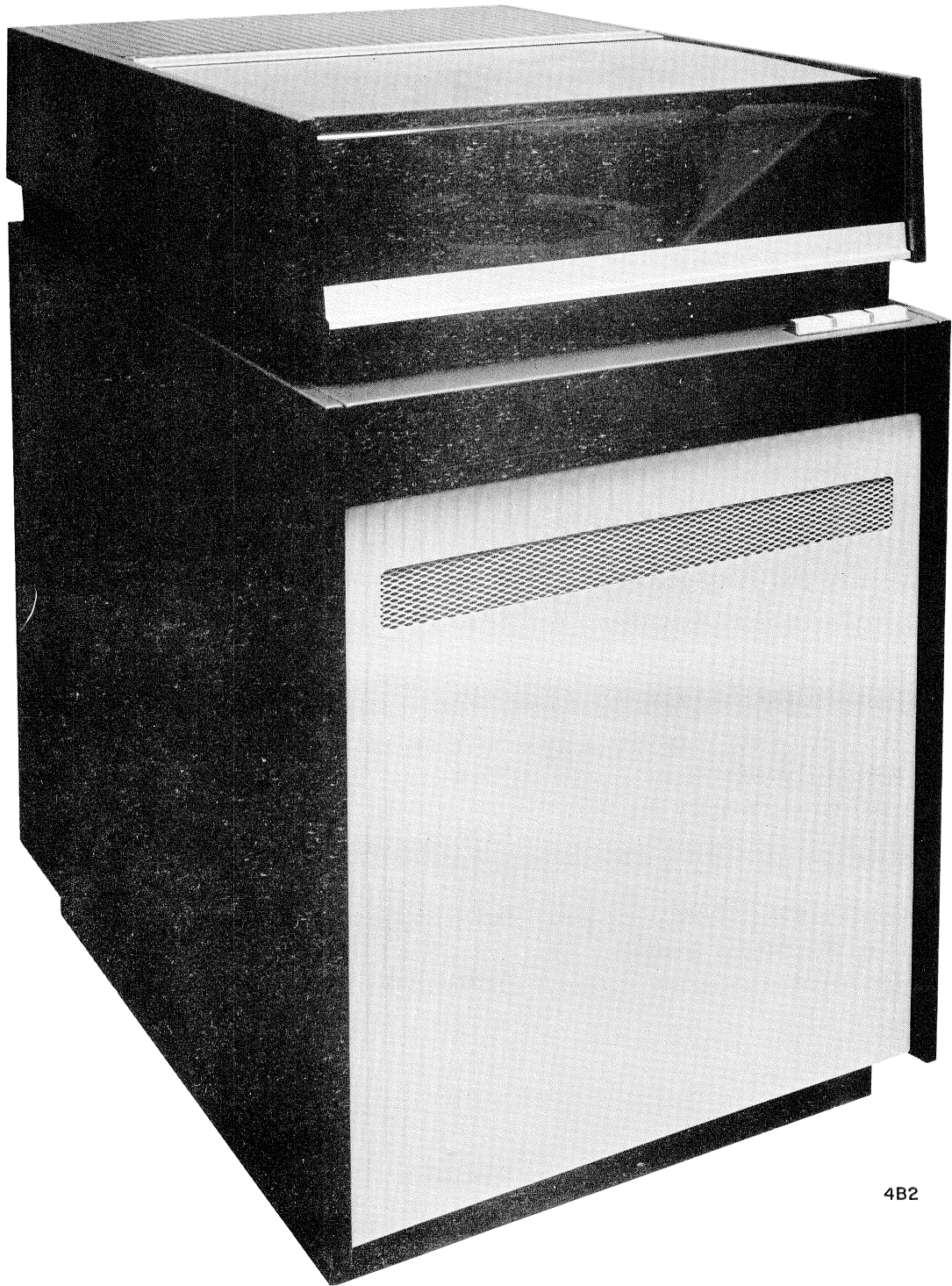

4B2

9465 DISK STORAGE DRIVE

SECTION 1

INTRODUCTION

INTRODUCTION

SCOPE

This manual is a technical guide for customer engineers and other technical personnel directly involved with maintaining the disk storage drive. The manual is divided into seven sections: Introduction, Operation, Functional Description, Interface, Preventive Maintenance, Maintenance Procedures, and Special Maintenance Information.

DESCRIPTION

The CONTROL DATA® 9465 Disk Storage Drive is a high-speed, random-access, input/output device to be used with a central processor.

The 9465 stores information on a disk pack in the form of magnetized bits or spots. Disk packs may be freely and quickly interchanged between disk storage drives of the same type using the same addressing scheme. Disk packs also allow unlimited shelf storage of input data files as well as random access to the data. The data on a disk pack, although permanent, may be erased and replaced by new information if desired.

The 9465 may be used with computers in an on-line capacity or with external equipment in an off-line processing system. Transfer of data and exchange of control information from computers or off-line equipment to the disk storage drive is via a separate external control unit. The control unit provides the timing information necessary to buffer and control the flow of information into and out of the disk storage drive.

ASSOCIATED PUBLICATIONS

Customer engineering manuals used in conjunction with this maintenance manual are:

- 9465 Diagrams and Wire List, Pub. No. 41248800

The diagram section contains the logic and electrical schematics of the major assemblies of the disk storage drive. The wire list section contains information such as conductor origin and destination, color coding, length, and size. The circuit description explains logic and electrical schematics and is located in the diagrams section.

- 9465 Illustrated Parts List, Pub. No. 40860200

The parts list contains part numbers, identification views, and identification information.

- Disk Storage Drives (OEM), 1604 Series Logic Modules Manual, Pub. No. 40826700

The electrical schematics, component layout diagrams, and operational description of the logic cards used in Control Data peripheral equipment are found in this manual.

Refer to the Control Data Literature Catalog for the latest publication numbers and revision levels of the associated publications.

SPECIAL TOOLS

TOOL	CONTROL DATA PART NUMBER
CE Disk Pack	84357500
Disk Pack Runout Gage	84357600
Plastic Feeler Gage (0.001 in.)	12205637
Plastic Feeler Gage (0.002 in.)	12205636
Plastic Feeler Gage (0.003 in.)	12205635
Plastic Feeler Gage (0.005 in.)	12205633
Tachometer	84362900
Lock Wedge Removal Tool	84371800
Extraction Tool	12210915
Push-Pull Gage	12210797
Head Plug Adapter	46812200
Compression Tool	84356100
Torque Allendriver (capable of measuring 10 in. -lbs.)	84255000
Oscilloscope, dual trace, Tektronix 546 with type CA preamplifier (or equivalent)	

EQUIPMENT SPECIFICATIONS

CHARACTERISTIC	SPECIFICATION
Capacity/Data Format	
Total Capacity	7,250,000 characters
Bits per Character/Byte	8
Characters per Disk Surface	725,000
Characters per Track	3625
Processing Speed	
Access Time (max)	135 ms
One-Track Access Time	24 ms (max)
Average Access Time	85 ms
Recording	
Mode	Double frequency
Density	765 bpi (outer track) and 1105 bpi (inner track)

EQUIPMENT SPECIFICATIONS (Cont'd)

CHARACTERISTIC	SPECIFICATION
Bit Rate	1.25 MHz
Data Transfer Rate	156,250 characters/sec
Disks	
Number of Disks	6
Usable Disk Surfaces	10
Tracks per Disk Surface	200 (+3 spare)
Speed	2400 ± 48 rpm
Diameter	14 in.
Coating Material	Magnetic oxide
Heads	
Total	10
Read/Write Width	0.008 in.
Total Erase Width	0.012 in.
Erase Tunnel Width	0.005 in.
Track Spacing	0.010 in.
Addressing	Optional
Operator Controls	START switch/indicator Unit Number indicator FAULT switch/indicator
Physical	
Height	41 in. (104 cm)
Width	24 in. (61 cm)
Depth	36 in. (91.4 cm)
Weight	480 lb (217.7 kg)
Environment	
Operating	60° to 90° F (20°F/hr-max gradient) 10% to 80% relative humidity.
Nonoperating	-30° to 150°F 5% to 98% relative humidity
Heat Dissipation	3000 BTU/hr
Electrical	
Power Sources	380 volts, 50 Hz, 3-phase (P01) 220 volts, 50 Hz, single-phase (P10)

EQUIPMENT SPECIFICATIONS (Cont'd)

CHARACTERISTIC	SPECIFICATION
Running Current	2.5 amps or 1.0 amp/phase (380v) 2.0 amps (220v)
Starting Current (max)	18 amps (one phase of 380v)
Input/Output Connectors	Three connectors (two for cable A and one for cable B) located at rear of logic chassis. Pin assignments according to Table 1-1. Connections according to Figure 4-1.

TABLE 1-1. INPUT/OUTPUT CONNECTOR PIN ASSIGNMENTS

CABLE A INTERFACE (J100-J101)		CABLE B INTERFACE (J102)	
PIN	FUNCTION	PIN	FUNCTION
1-4	Address and Control Line Bit 0	A-B	Unit Select
2-5	Address and Control Line Bit 1	D-E	Unit Selected
3-7	Address and Control Line Bit 2	C-F	Spare
8-12	Address and Control Line Bit 3	H	Twisted Pair Shield
10-13	Address and Control Line Bit 4	J	Termination Power Shield
11-14	Address and Control Line Bit 5	K	Spare
15-18	Address and Control Line Bit 6	L	Termination Power*
16-20	Address and Control Line Bit 7	M	GND Termination Power*
17-21	Cylinder Select	N	Termination Power*
22-25	Head Select	P	Sequence Lines Shield
23-26	Difference Select	R	Sequence Line
24-27	Control Select	S	Spare
28-31	Read Cylinder Select	T	Sequence Line
29-32	Unit Has Been Not Ready	U	Sequence Line
30-33	Pack Unsafe	V	Sequence Line
34-37	Selected Seek Error	W	Sequence Line
35-38	Spare	X	Sequence Line
36-39	Jumpered		
40-43	Spare		*From Controller
41-44	Spare		
42-45	Spare		
46-49	Spare		
47-50	End of Cylinder		
48-51	Write Data		
52-55	Read Data		
53-56	Spare		
54-57	Spare		
58-62	Selected On Cylinder		
59-63	Selected Unit On Line		
60-64	Selected Index		
65-70	Spare		
66-71	Spare		

TABLE 1-1. INPUT/OUTPUT CONNECTOR PIN ASSIGNMENTS (Cont'd)

CABLE A INTERFACE (J100-J101)		CABLE B INTERFACE (J102)	
PIN	FUNCTION	PIN	FUNCTION
67-72	Spare		
73-76	Spare		
74-77	Spare		
75-78	Spare		
79	Termination Power		
80	GND Termination Power		
82	Termination Power		

SECTION 2

OPERATION

OPERATION

This section provides the operator with general operating instructions for the disk storage drive and a functional description of the controls and indicators of the unit.

GENERAL OPERATING INSTRUCTIONS

APPLICATION OF POWER

The power distribution circuit contains three interlock switches. The front (plexiglass) and top rear covers must be closed and a disk pack must be installed before power can be applied to the spindle drive motor.

1. Make certain that the disk storage drive power cord is connected to the correct external ac power source (check unit identification plate for required voltage and frequency).
2. To gain access to the power supply control panel, grasp the top edge of the cabinet rear panel and pull outward.

CAUTION

If the disk storage drive is connected to the controller in series with other units, do not turn the power supply MAIN POWER circuit breaker on or off while one of the other units is reading or writing. This may cause the disk storage drive or the controller to make errors. Refer to the Diagrams and Wire List Manual (see Section 1) for additional information on the Power-On sequence.

3. Set the power supply MAIN POWER circuit breaker to ON. The adjacent neon phase and +20Y indicators light to verify the application of external ac power.
4. Set the remaining power supply circuit breakers to ON. The related indicators light to verify the presence of each voltage.

5. Install the cabinet rear panel. Install a disk pack.

NOTE

Maximum operational stability is achieved after the unit has reached thermal stability. The warmup time (spindle rotating) is approximately 45 minutes if the ac power has been removed for longer than 4 hours. It is recommended that the power supply remain energized (MAIN POWER and DC INPUT POWER circuit breakers ON) or that the warmup period be allowed prior to a Read/Write operation.

6. Press the START switch to apply power to the spindle drive motor and start the First Seek operation. The Unit Number indicator lights when the read/write heads are loaded. When the carriage stops at Track 00, the unit is ready to receive a Read, a Write, or a Seek command from the controller.

DISK PACK INSTALLATION AND REMOVAL

Installation

Prior to installing a disk pack, set the power supply MAIN POWER and DC INPUT POWER circuit breakers to ON. This applies the spindle brake. Do not press the START switch/indicator. Make certain that the disk pack to be installed has been cleaned according to the preventive maintenance schedule, Section 5.

1. Lift the disk pack by the plastic cannister handle.
2. Unscrew the bottom dust cover from the disk pack using the knob in the center of the cover. Set the cover aside.
3. Raise the plexiglass cover on the disk storage drive, Figure 2-1.

CAUTION

Avoid abusive contact between the disk pack and the spindle assembly. Avoid touching either the spindle assembly or the mating surface of the disk pack; corrosion may result.

4. Place the disk pack onto the spindle.
5. Twist the plastic cannister handle clockwise to lock the disk pack in place. Make certain the cover has been rotated clockwise to a positive stop.

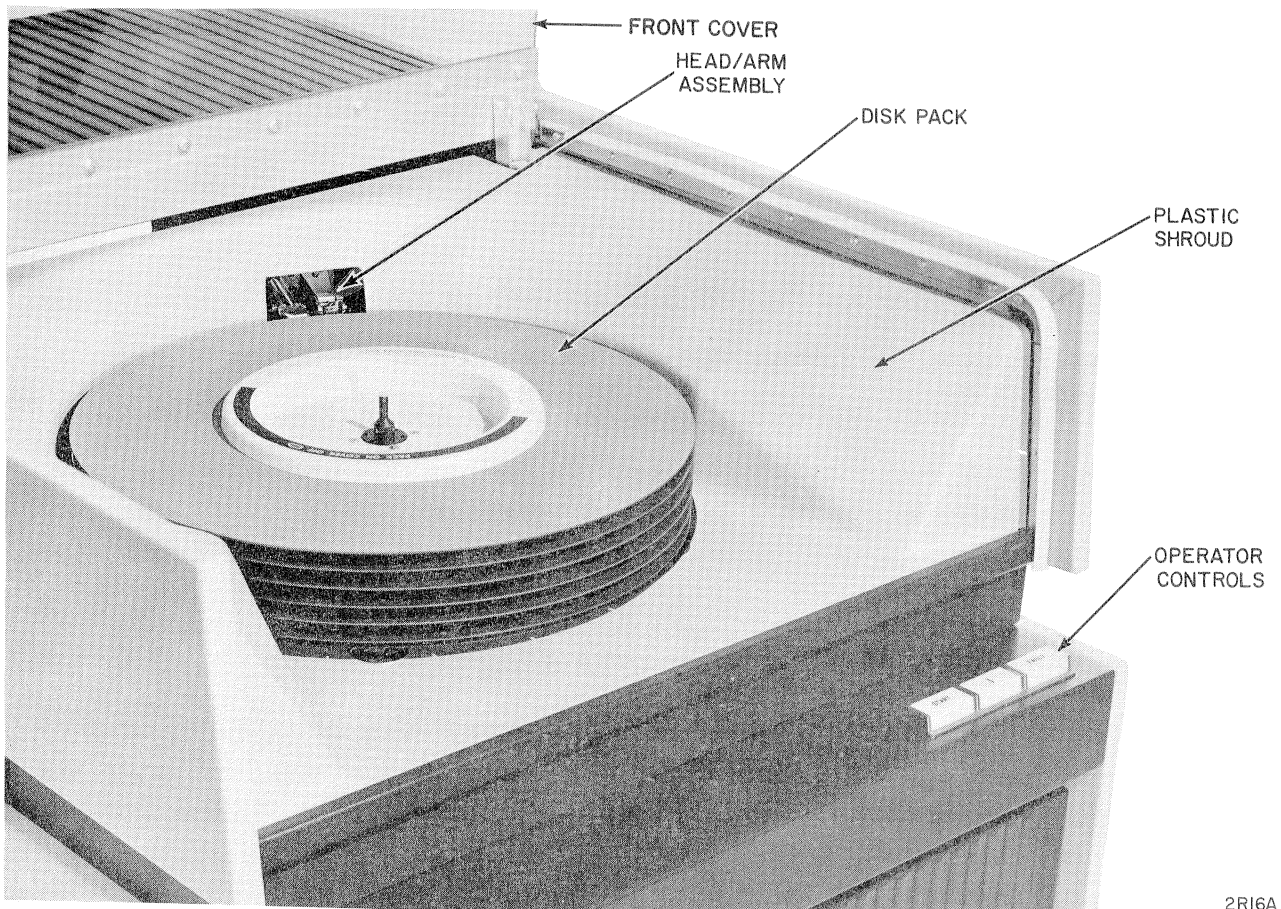

2R16A

Figure 2-1. Disk Pack Load and Unload Mechanics

6. Lift the cannister clear of the disk pack and set it aside.
7. Close the plexiglass cover immediately to prevent the entry of dust and the contamination of the disk surfaces.

Removal

Before removing the disk pack, make certain that it has stopped rotating. The power supply MAIN POWER and DC INPUT POWER circuit breakers should remain ON to apply the spindle brake.

1. Raise the plexiglass cover on the disk storage drive.
2. Place the plastic cannister over the mounted disk pack so that the post protruding from the center of the disk pack is received into the cannister handle.

3. Twist the cannister handle counterclockwise until the disk pack is free of the spindle.

CAUTION

In the following step, avoid abusive contact between the disk pack and the spindle assembly.

4. Lift the cannister and the disk pack clear of the spindle.
5. Close the plexiglass cover over the shrouded area.
6. Place the bottom dust cover in position on the disk pack and tighten it.
7. If operation (requiring further use of the disk storage drive) are complete, set the power supply MAIN POWER circuit breaker to OFF.

CONTROLS AND INDICATORS

Manual controls and indicators (Figure 2-2) used in operating the disk storage drive are mounted in front of the plexiglass cover. Additional controls and indicators (used by authorized maintenance personnel only) are located on the logic chassis maintenance panel (Figure 2-3) and the power supply control panel (Figure 2-4). A brief functional description of these controls and indicators follows Figure 2-4.

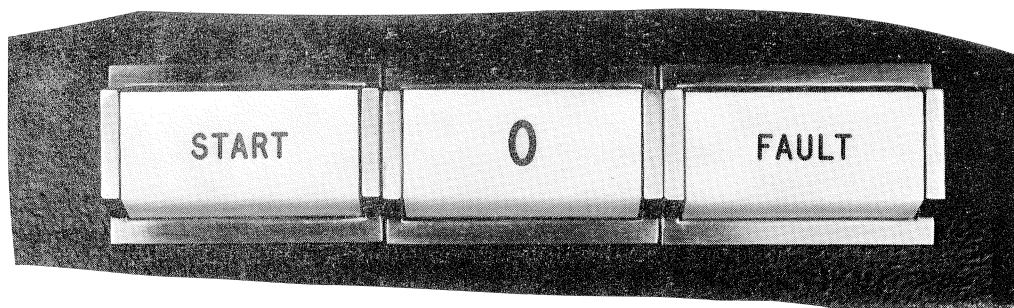
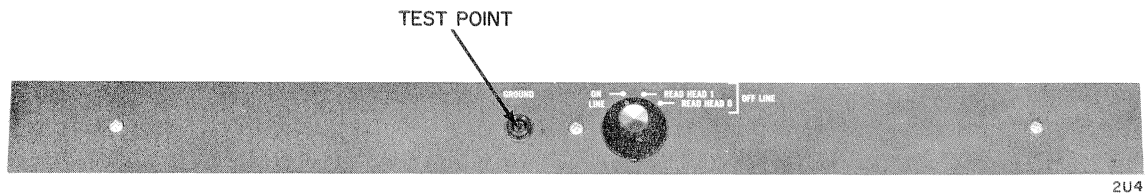
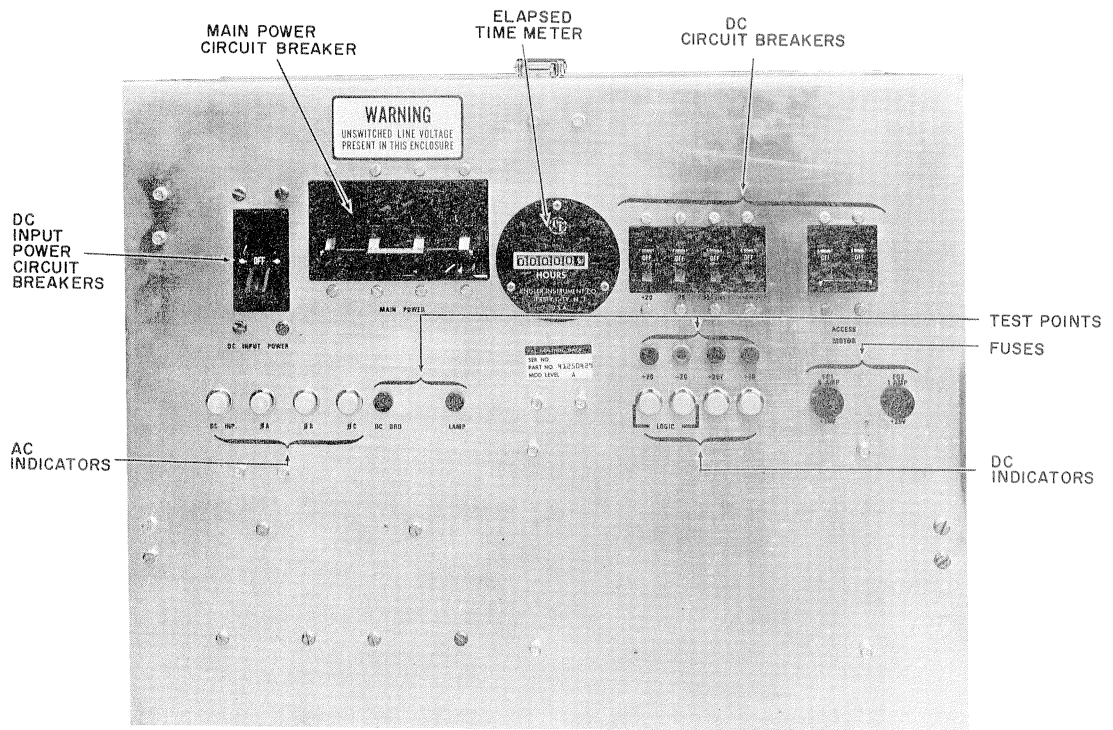

Figure 2-2. Operator Panel



2U4

Figure 2-3. Logic Chassis Maintenance Panel



485

Figure 2-4. Power Supply Control Panel

CONTROL AND INDICATOR FUNCTIONS

CONTROL OR INDICATOR

FUNCTION

Operator Panel

START switch/indicator

Energizes (when pressed to light) the spindle drive motor to begin a First Seek sequence if the disk pack is in place, and all unit interlocks are closed. De-energizes (when pressed to extinguish) the spindle drive motor causing the heads to unload and the carriage to retract.

Unit Number indicator

The number assigned to the disk storage drive unit when several units are used in the same system. The indicator lights when the disk drive heads are loaded. All disk storage drives leave the factory as unit 0. Wiring (at the controller) and indicator lens changes are necessary to change the unit number.

FAULT switch/indicator

Lights when the following fault conditions exist:

1. More than one head is selected.
2. Read and Write selects exist at the same time.
3. Read and Erase selects exist at the same time.
4. Erase is selected with no write driver.
5. Erase is selected in combination with both write drivers.
6. One or both write drivers are on with no erase driver.
7. Read, write, or erase is selected without an On Cylinder signal.

CONTROL AND INDICATOR FUNCTIONS (Cont'd)

CONTROL OR INDICATOR	FUNCTION
FAULT switch/indicator (Cont'd)	The Fault flip-flop in the logic section is cleared by pressing the FAULT switch/indicator. The Fault flip-flop remains cleared until the original source of the problem reappears.
<u>Power Supply Control Panel</u>	
MAIN POWER circuit breaker	Controls the external 380 volts to the disk storage drive unit. Inhibits application of external 220 volts when set to OFF.
DC INPUT POWER Circuit breaker	Controls the external 220 volts to the disk storage drive. Functional only when the MAIN POWER circuit breaker is set to ON.
+20 vdc circuit breakers	Control the application of these voltages to the logic section.
+40 vdc circuit breaker	Controls the application of this voltage to the write supply.
NOTE	
An indicator is provided with each of the above circuit breakers. Each indicator lights when the corresponding voltage is present. Test points are also provided to test the various voltage levels.	
DETENT circuit breaker	Controls the +20X vdc to the detent magnet.
ACCESS MOTOR circuit breaker	Controls the +20X vdc to the access motor.
F01/5 amp/+20 fuse	Protects the +20Y vdc line to the head and cam latch solenoids.

CONTROL AND INDICATOR FUNCTIONS (Cont'd)

CONTROL OR INDICATOR

FUNCTION

F02/1 amp/+20v fuse

Protects the +20X vdc line to the sector solenoids.

NOTE

F05 and F06 are located behind the Power Supply Control Panel on the right side of the chassis assembly.

F05/1 amp/24 vac fuse

Protects the 24 vac line to the brush motor.

F06/5 amp/+40v fuse

Protects the +40 vdc line to the spindle motor.

Elapsed Time meter

Indicates the spindle drive motor operating time (pack rotating).

Spindle Lock Disable

Switch is located directly below the operator panel controls. The switch disables the brake for purposes of disk pack inspection and maintenance. When in the OFF position the brake is disabled. The switch must be in the ON position for all other operations.

Logic Chassis Maintenance Panel

OFF LINE/ON LINE switch

Transfers the control of the disk storage drive unit Read functions from the controller to the unit itself, and vice-versa. When the switch is in one of the two OFF LINE positions, a Read operation may be performed from either head 0 or head 1 as selected.

Actuator Assembly

Track indicator dial

The dial is etched on the timing disk (Figure 3-15) and indicates the track number at which the carriage is detented. The dial is read at the track indicator index (overhangs timing disk).

SECTION 3

FUNCTION DESCRIPTION

FUNCTIONAL DESCRIPTION

Functional description is divided into five parts. The first part considers the disk storage drive in terms of the general functions it performs and the signals (Figure 3-1 and Table 3-1) exchanged with the controller. (For a detailed description of the logical functions of the unit, refer to the Diagrams and Wire List Manual.) The second part relates the major assemblies of the unit to the previously discussed functions. The last three parts (unit cooling, the disk pack, and data recording) cover subjects which are not functional entities, but are an aid in understanding overall operation.

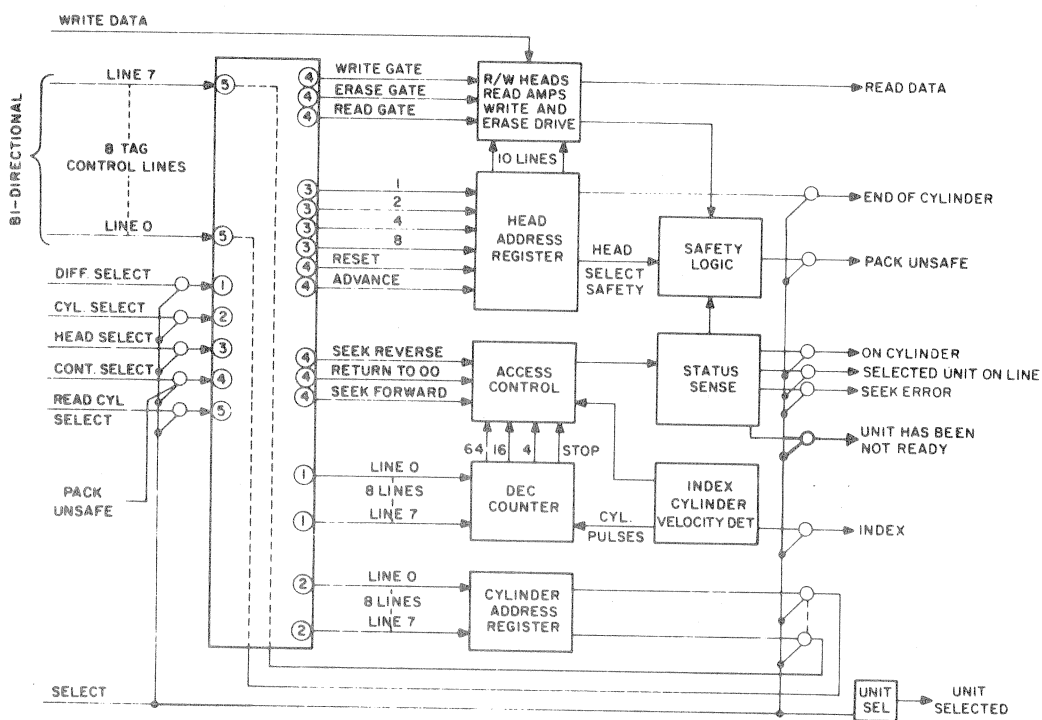

4B4A

Figure 3-1. General Block Diagram

FUNCTIONS

FIRST SEEK AND UNIT SELECT

The First Seek function includes the preliminary operations the disk storage drive must perform before it can effectively respond to a Read, a Write, or a Seek command from the controller.

In preparation for the First Seek, the controller provides a sequence voltage to the disk storage drive power supply. This signal causes the power supply to perform a Power-On sequence. After the disk pack is up to speed, the carriage (mounting point of the read/write heads) is driven forward into the disk pack until the read/write heads are loaded (latched in the read/write position over the disk surfaces). When the heads are loaded, carriage motion is reversed and the read/write heads are positioned over cylinder zero of the disk pack and the spring-loaded pawl engages the detent gear. An On Cylinder signal is sent to the controller 10 ms later. The disk storage drive is now ready to perform a Read, Write, Direct Seek or Return to Zero operation.

TABLE 3-1. INPUT/OUTPUT LINES

SIGNAL		FUNCTION	
<u>Bidirectional Lines</u> Address and Control		Information carried by the bidirectional lines is coupled by five select (enable) signals. The influencing enable signal must be known before information on a bidirectional line can be interpreted. The five enable signals are defined under Input Lines (page 3-3). The information coupled by each enable signal is as follows:	
Address/ Control Bus	Read Cylinder Select, Difference Select, or Cylinder Select	Head Select	Control Select
Bit 0	1	1	Write Gate - A "1" input on this line enables the write drivers.
Bit 1	2	2	Read Gate - A "1" input on this line enables the digital read data line.
Bit 2	4	4	Seek Forward - A "1" input on this line initiates forward carriage movement.

TABLE 3-1. INPUT/OUTPUT LINES (Cont'd)

SIGNAL		FUNCTION	
Address/ Control Bus	Read Cylinder Select, Difference Select, or Cylinder Select	Head Select	Control Select
Bit 3	8	8	Reset (Hd Reg)- A "1" input on this line sets the Head Address register to zero.
Bit 4	16	Not Used	Erase Gate- A "1" input on this line enables the erase driver to pass current through the head erase coil.
Bit 5	32	Not Used	Seek Rev. - A "1" input on this line initiates reverse carriage movement.
Bit 6	64	Not Used	Return to 00- A "1" input on this line initiates carriage movement to cylinder 00.
Bit 7	128	Not Used	(Head) Advance- A "1" input on this line increments the Head Address register so that the next head in order can be selected.
<u>Input Lines</u>			
Read Cylinder Select		A "1" input on this line enables the address and control line transmitters of the selected disk storage drive. Information transmitted to the controller through these lines is the current cylinder address.	
Difference Select		A "1" input on this line indicates that the address and control lines contain the difference address from the controller. This address is the difference between the controller's current cylinder request and the disk storage drive's present cylinder location.	
Cylinder Select		A "1" input on this line indicates that the address and control lines contains the controller's current cylinder request.	
Head Select		A "1" input on this line indicates that the address and control lines contains the head select information.	

TABLE 3-1. INPUT/OUTPUT LINES

SIGNAL	FUNCTION
Control Select	A "1" input on this line indicates that the address and control lines contain control information.
Write Data	Carries information to be written from the controller to the disk storage drive.
Unit Select	This line is used to select the disk storage drive.
<u>Output Lines</u>	
Read Data	Carries digital information read from the disks to the controller.
On Cylinder	Indicates that the positioning mechanism has stopped and the read/write heads have reached the addressed cylinder.
Unit Has Been Not Ready	A "1" output indicates that the disk storage drive has not received a Unit Select since coming on line.
End of Cylinder	A "1" output is provided when the Head Address register goes from 9 to 10 as it is incremented (by Advance signal) in a multi-track operation requiring the use of sequential head addressing.
Seek Error	A "1" output indicates that the selected disk storage drive unit was unable to complete a Seek operation to the point of returning an On Cylinder signal to the controller. A Return to Zero Seek command (sent to the unit indicating a seek error) clears the Seek Error condition, returns the heads to cylinder 00, and enables an On Cylinder signal to be sent to the controller.
Unit Selected	This line is used by the controller to check if a disk storage drive is selected.
Selected Unit On Line	<p>A "1" output is available whenever all three of the following conditions occur:</p> <ol style="list-style-type: none"> 1. Heads are loaded and spindle motor is up to speed.

TABLE 3-1. INPUT/OUTPUT LINES (Cont'd)

SIGNAL	FUNCTION
<p>Index</p> <p>Pack Unsafe</p>	<p>2. A disk pack is loaded on the disk drive unit.</p> <p>3. ON LINE/OFF LINE switch in ON LINE position.</p> <p>Provides a track reference mark from the selected disk storage drive unit to the controller. All other track reference marks are measured from this point.</p> <p>A "1" output indicates that the selected disk storage drive unit has one or more fault conditions. These conditions include:</p> <ol style="list-style-type: none"> 1. More than one head selected 2. Both read and write gates up at same time 3. Erase and no write driver on 4. Erase and both write drivers on 5. One or both write drivers on and no erase driver on 6. Read, write, or erase gate on and no On Cylinder 7. Both read and erase gates up at same time

DIRECT (FORWARD/REVERSE) SEEK

The Direct Seek function involves the operations that must be performed to move the read/write heads from their current cylinder to the cylinder specified by the controller.

The Read Cylinder Select is applied to the selected storage drive in order to start a Direct Seek. This signal enables the control line transmitters in the Cylinder Address register and causes the disk storage drive to transmit the current cylinder address to the controller. The controller then determines the number of cylinders that must be traversed to reach the desired cylinder. For example, if the heads are presently at cylinder 10 and the desired cylinder is 31, the difference address is 21. The difference address is coupled to the disk storage drive by the Difference Select signal which allows the difference address to be registered in the Decrement counter. Once the difference address is in the Decrement counter, the Cylinder Select signal is applied to the disk storage drive. This signal causes the transfer of the controller's current cylinder address into the disk storage drive Cylinder Address register.

The Control Select signal is now applied. This signal couples the Forward or Reverse (as applicable) command, and the seek is initiated under control of the Access Control circuit. At this point, the controller may (assuming it has the capability) elect to proceed to the next unit and command a Read, a Write, or a Seek operation while the previous unit performs the assigned seek, or it may wait for the completion of the seek by this unit. In either case the seek continues in the same manner.

Assume that the number of cylinders (or tracks, refer to Cylinder Concept paragraph) to go is greater than 64. The access motor driving the carriage accelerates toward maximum velocity. Track pulses are supplied to the Decrement counter from a track photocell (part of Index Cylinder Velocity Detector) as the carriage is moved to reposition the heads. Each track pulse decreases the Decrement counter content by one. A speed photocell (also part of Index Cylinder Velocity Detector) provides pulses representative of the rate in ips at which the read/write heads are approaching the desired cylinder. When the counter content is less than 64, the carriage is dynamically braked to a speed of 15 ips. The motor now drives at 15 ips until the number of tracks left is less than 16. The carriage is then dynamically braked to a speed of 6 ips and continues at this speed until three tracks remain. At this point, the carriage is braked to approximately 2 ips. This speed is maintained until the desired cylinder is reached.

When the selected track is reached, the spring-loaded detent pawl engages the detent gear, positioning the heads precisely over the selected track. Ten ms after the carriage stop, an On Cylinder signal is supplied to the controller. The signal indicates that the disk storage drive is ready to perform a Read or Write operation.

RETURN TO ZERO SEEK

The Return to Zero Seek function allows a controller to re-establish the location of the read/write heads if, for some reason, the location is in doubt or if an illegal seek length caused a Seek Error signal to occur.

When a Return to Zero Seek is selected, the Decrement counter and the Cylinder Address register are set to zero and the carriage is driven toward track zero at 6 ips. When light is sensed by the home cell (photocell that senses when heads are outside of recordable area of disk surfaces), the access motor drive current is reversed and the carriage is driven forward until track zero is reached. The detent pawl is dropped, and 10 ms later the On Cylinder signal is supplied to the controller. The disk storage drive is now ready to perform a Seek, a Read, or a Write operation.

READ/WRITE/ERASE

The On Cylinder signal indicates to the controller that the disk storage drive has completed the Seek operation and is waiting for further instructions. If the next operation to be performed is a Read or Write, the sequence of events depends on the optional addressing format (address code or sector mark) used on the disk pack.

If the address code format is used, a Write operation starts when the Control Select signal enables the Head Select signal. At this point the latter signal enables the Head Select lines into the Head Address register (which has stored the desired Head Address during head set and start seek time). The Read Gate signal is enabled 60 usec (minimum) after head select. As each record is reached, the address is read and compared by the controller, with the address of the desired record. When comparison indicates that the address just read was the address of the desired record, the Read Gate signal is dropped and Control Select enables the Write Gate (enabling the Write Drive circuit).

Data from the controller is then written on the selected record. Erase current is applied to the erase head during the Write operation to ensure proper narrowing of the recorded data track.

If the sector mark format is used, a Write operation starts with the Head Select signal. The controller then waits for an Index signal after which it begins counting Sector Mark signals (both signals derived from sector/presector photocell, part of Index Cylinder Velocity Detector). When the desired number of Sector Marks have been counted, the Control Select enables the Write Gate and data is written in the same manner as for the address code format.

A Read operation is performed in much the same manner as a Write operation. The difference in the address code format is that the Write Gate signal is never enabled (Read Gate stays on constantly). In the sector mark format the difference is that Control Select enables the Read Gate instead of the Write Gate when the desired number of Sector Marks have been counted.

ASSEMBLIES

POWER SUPPLY

The disk storage drive has a self-contained power supply (Figure 3-2) located behind the rear panel of the machine. The power supply is a drawer-type unit that mounts on self-lubricating, slide-borne rollers. The front panel of the unit is hinged and latched to allow access to the interior wiring and components.

The power supply is supplemented by an auxiliary power unit which is located below the main power supply on the disk storage drive chassis. Both the main power supply and the auxiliary power unit are completely solid state to provide low heat dissipation and high reliability to the operating system.

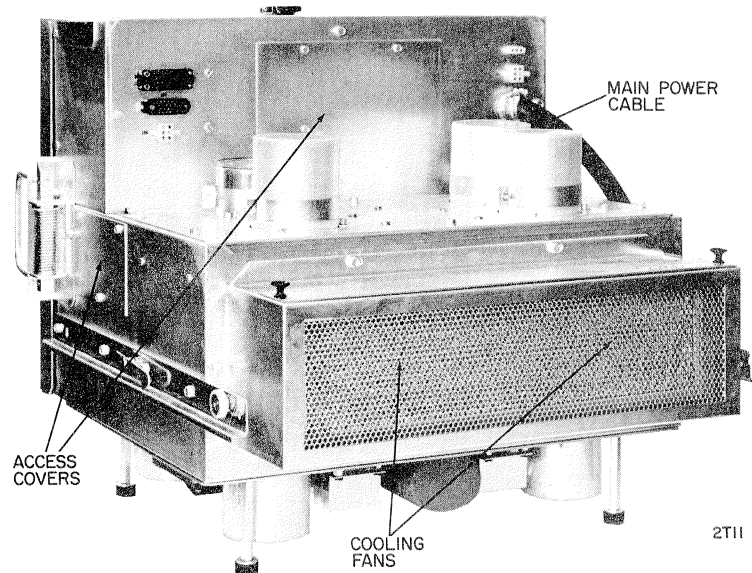

Figure 3-2. Power Supply

The power supply uses two different input voltages (Figure 3-3). Application of the 380-volt input power is controlled by the MAIN POWER circuit breaker. This input is applied to the blower motors in the logic chassis and the two fans in the power supply, and through a power sequence relay to the spindle motor. No part of the 380-volt input is used in developing dc power.

The 220-volt input power is controlled by the DC INPUT POWER and MAIN POWER circuit breakers and is applied to the primary windings of ferroresonant transformer T01. Since T01 is a ferroresonant transformer, the voltage coupled to the secondary tends to remain constant, regardless of the voltage variation of the applied signal or the load applied to the secondary. The voltage developed across the secondary of T01 is coupled to the power supply rectifier diodes, the primary windings of transformer T02, and to the auxiliary power supply for further voltage development. Also coupled from the secondary of T01 is 24 vac to the pack brush motor.

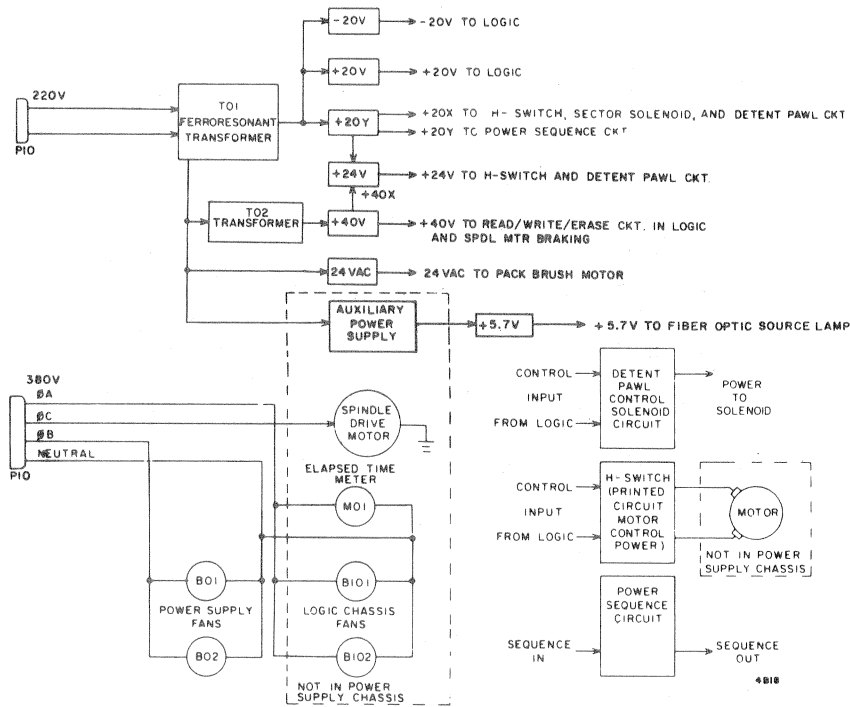

Figure 3-3. Power Supply General Block Diagram

The various dc voltages developed by the power supply are used by all major assemblies of the disk storage drive. The voltages developed (Figure 3-3) are an adjustable \pm vdc which is supplied to the logic chassis, +24 vdc and +20X vdc for the access motor and detent solenoid, +20Y vdc for the power sequencing circuit, and +40 vdc which is supplied to the logic write circuit and the dynamic braking circuit. These voltages are sequenced and coupled to the related circuits by a series of relays.

The auxiliary power supply develops +5.7 vdc which is provided for the fiber optics source lamp.

Refer to the related Diagrams and Wire List Manual (see Section 1) for a detailed description of the power sequence and distribution functions performed by the power supply.

LOGIC CHASSIS

All logic cards for the disk storage drive, except the read/write logic cards, are mounted on a single forced-air-cooled chassis (Figure 3-4). This assembly is located behind the front panel of the machine.

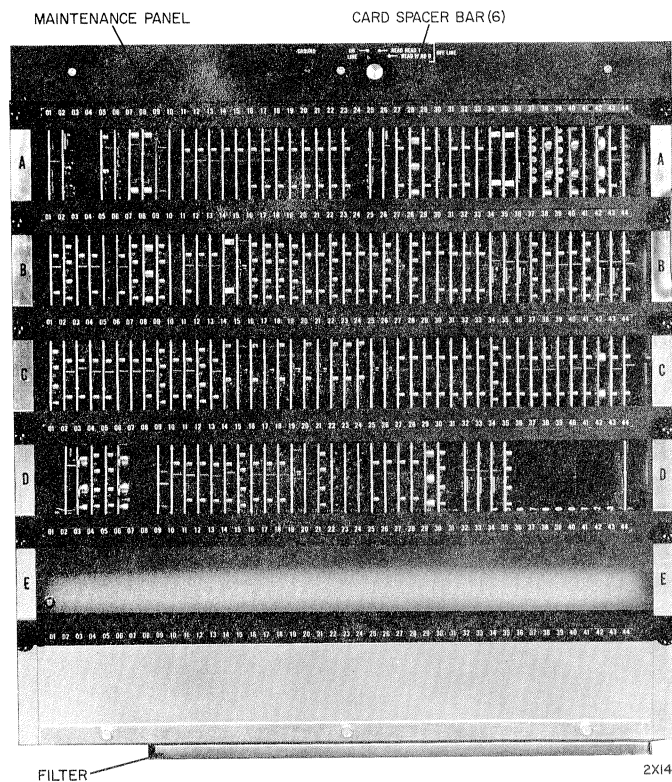

Figure 3-4. Logic Chassis, Front View

The chassis is hinged, latched and equipped with a removable plate to allow access to the wiring.

The logic chassis contains circuit cards to control printed circuit motor velocity, head positioning, head loading, head selecting, seek overlap, and data channeling. The logic chassis maintenance panel located along the top edge of chassis contains the switch that controls the on-line/off-line status of the unit. The off-line positions of this switch are used only during maintenance situations.

Figure 3-5 is a rear view of the logic chassis showing the connector panel at which the system interface connections are made. Refer to the related Diagrams and Wire list Manual (see Section 1) for a detailed description of the functions performed by the logic.

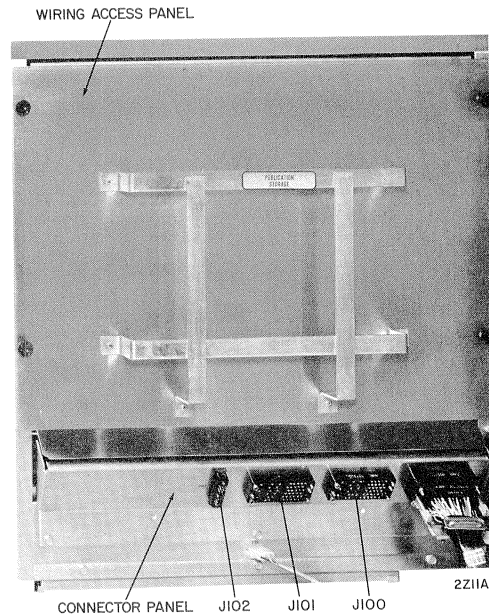

Figure 3-5. Logic Chassis, Rear View

READ/WRITE LOGIC CHASSIS

The read/write logic chassis is mounted on the main deck adjacent to the actuator. The logic cards of this chassis are involved in all Read and Write operations. Access to the cards is gained by raising the top rear cover of the disk storage drive. Refer to the related Diagrams and Wire List Manual (see Section 1) for a detailed description of the functions performed by this logic.

SPINDLE AND BRAKE

The spindle and brake assembly is the physical interface between the disk storage drive and the disk pack. The conical surface of the spindle cone (Figure 3-6) mates directly with the cone-shaped opening in the center of the disk pack.

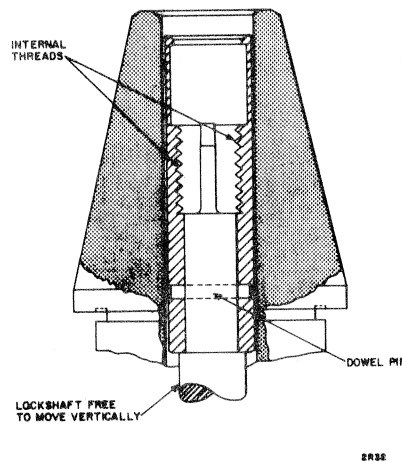

Figure 3-6. Spindle Cone

Starting in the spindle cone and running through the center of the spindle and brake assembly is the vertically free-floating lockshaft (Figure 3-7). The upper end of the lockshaft contains internal threads (Figure 3-6) that engage the external threads of a stud projecting from the disk pack. When the disk pack cannister cover handle is rotated clockwise, the spring-loaded lockshaft is pulled upward and the disk pack is pulled down. As a result, the conical surfaces of the disk pack and the spindle cone are engaged by a force of approximately 200 pounds. When the disk pack is fully engaged, a release mechanism in the cannister handle frees the cannister from the disk pack. The spindle drive pulley secures to the lockshaft. A flat belt links the spindle drive motor and the pulley.

The brake assembly, consisting of the spindle lock assembly and the spindle lock disk, mounts at the lower end of the spindle (Figure 3-7). The brake holds the spindle stationary to facilitate loading and unloading a disk pack. The spindle lock assembly, consisting of a pawl, a spring, a solenoid, and a switch, is the mechanism that engages the lock disk. The spring-loaded pawl engages the disk whenever the power

supply DC INPUT POWER and MAIN POWER circuit breakers are ON and the disk pack rotation is below a predetermined rpm (except during Power-On sequence). When the solenoid de-energizes, the spring-loaded plunger (on solenoid) pivots the pawl tip clear of the lock disk. The switch monitors the position of the pawl.

The Pack-On switch and a static discharge contact are also mounted on the spindle base. The static discharge contact mounts on a spring arm so that it is always in contact with the tip of the lockshaft. The Pack-On switch contacts are closed only when a disk pack is installed. The contacts are opened or closed by the vertical position of the lockshaft.

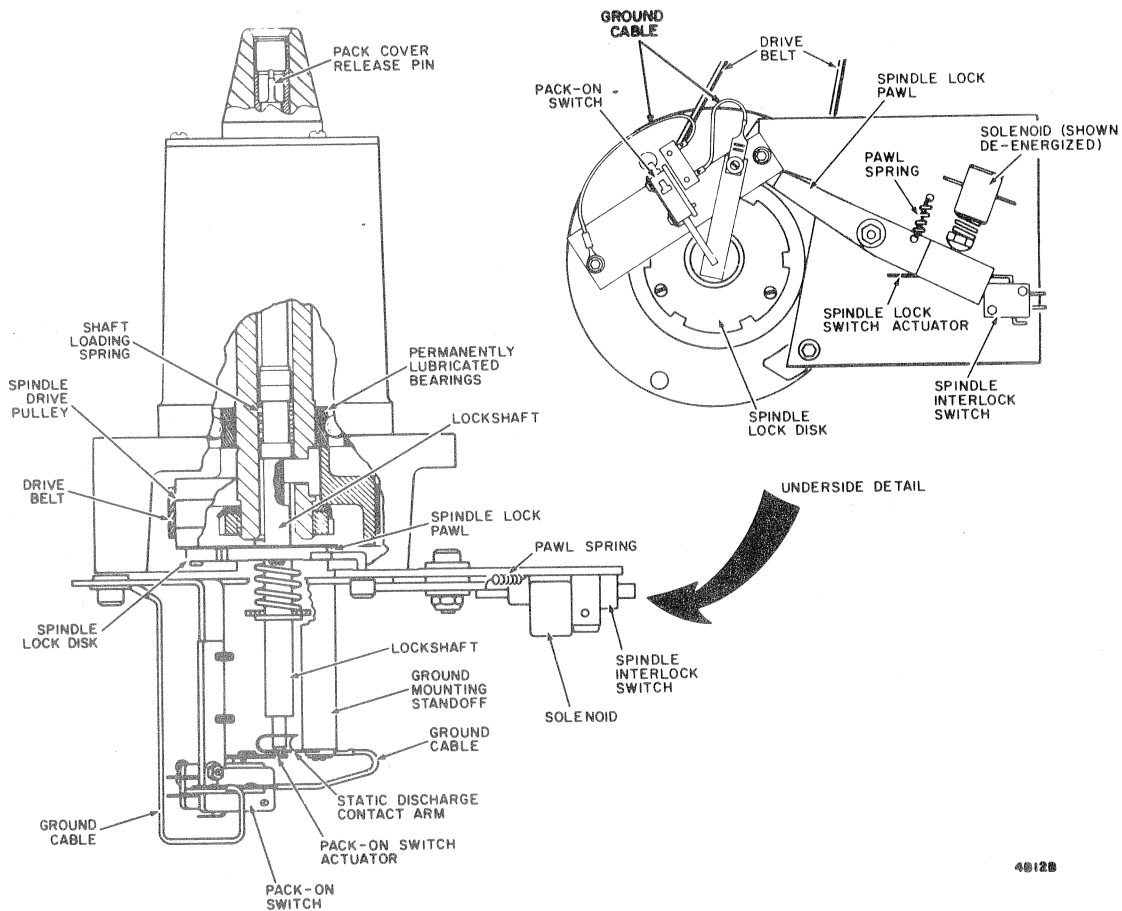

48128

Figure 3-7. Spindle and Brake Assembly

SPINDLE DRIVE MOTOR

The spindle drive motor, an induction-type, 1/3-hp unit which is mounted on the lower surface of the main deck, drives the disk pack. Thermal and electrical isolators are used when mounting the motor. These isolators allow separation of the signal ground from the ac motor ground, preventing ground loops, and reducing heat transfer to the main deck. The motor drives the pulley on the spindle and brake assembly by a flat, smooth-surfaced belt. The motor brings the disk pack up to normal operating speed in approximately 4 seconds.

The temperature of the motor is monitored by a thermal protection switch. To restore operation after an over-temperature condition, the red button on the lower end of the motor must be manually reset (pressed).

SECTOR SENSOR

The sector sensor originates pulses (in combination with the disk pack) used by the power supply to sequence power application and by the controller when reading or writing data on the disk pack.

The sensor consists of two photocells (sector and presector, each containing a fiber optic and a phototransistor), the sector solenoid, and a base block. The base block mounts on the main deck and the photocells are pivot mounted on the base block. The pivoting of the photocell is controlled by the sector solenoid and a spring. When power is applied the solenoid is energized and pivots the sector sensor so that the notched edge of the sector disk (part of the disk pack, Figure 3-8) comes between the fiber optics and the phototransistors of the photocells. When the solenoid is de-energized, the spring pulls the photocells from the edge of the disk pack. A disk pack may be installed or removed from the spindle without danger of damage when the sensor is retracted.

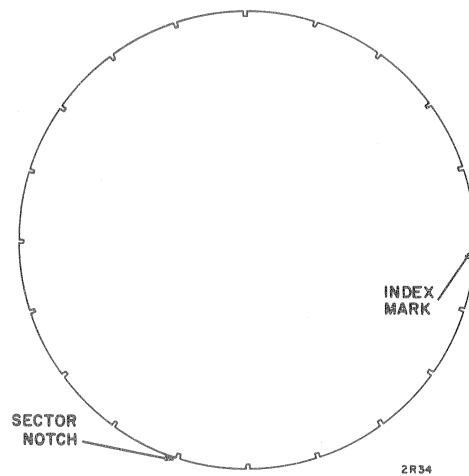

Figure 3-8. Sector Disk

The sector and presector photocells generate separate output pulses each time a notch on the sector disk passes. The repetition rate of these pulses is logically decoded to determine the speed of the disk pack. Further, the output pulses of both photocells indicate the starting point of various organizational segments of the disk pack. The sector pulse indicates the start of the cylinder of data. The starting point for a cylinder is called index. The index pulse occurs because the distance between the index mark notch (Figure 3-8) and the nearest sector notch is identical to the distance between the sector and presector photocells. This is the only point in a revolution of the disk pack at which simultaneous output pulses can occur.

The Pack Cover On switch is also mounted on the sector sensor base block. The switch contacts are closed only when the sector arm is fully extended into the disk pack sector disk. Closing the contacts allows the spindle drive motor to be energized and the pack to rotate.

FIBER OPTIC LAMP

The fiber optic lamp (Figure 3-9) generates light used to excite the sector, presector, track, speed, and home photocells.

The lamp assembly consists of five fiber optics, the lamp, and the lamp housing. The fiber optics (fiber bundles of glass) transmit the light from the source lamp to the five photocells.

BRUSH ASSEMBLY

The brush assembly (Figure 3-9) is used to clean the disk pack of loose particles prior to actual loading of the disk storage drive heads.

The brush assembly consists of motor, mechanical linkage, brushes and brush holders, reset switch, and base block. The base block mounts on the main deck and the brushes are pivot mounted on the base block. The pivoting of the brushes is controlled by the brush motor and linkage. Initiation of the brush cycle occurs when disk pack speed reaches 1900 rpm. A brush cycle consists of driving the brushes toward the center of the pack, reversing direction, and returning to the reset position. The cycle lasts approximately 52 seconds.

A detent mechanism in the brush assembly allows the operator to manually retract the brushes. The next power up sequence after the brushes have been manually retracted will not contain a complete brush sweep cycle but rather an automatic reset cycle to properly reset the brush assembly. The brush cycle will be normal in subsequent power-up sequences.

ACTUATOR

The actuator assembly (Figure 3-9) loads (to the read/write position) and unloads (to prevent impact with the disk surfaces) the read/write heads, drives the heads to the correct data track at speeds proportional to the distance to be traveled, and accurately positions and holds the head over the track as data is read or written. The actuator consists of three subassemblies: the carriage, the carriage mount, and the carriage drive and positioning mechanism.

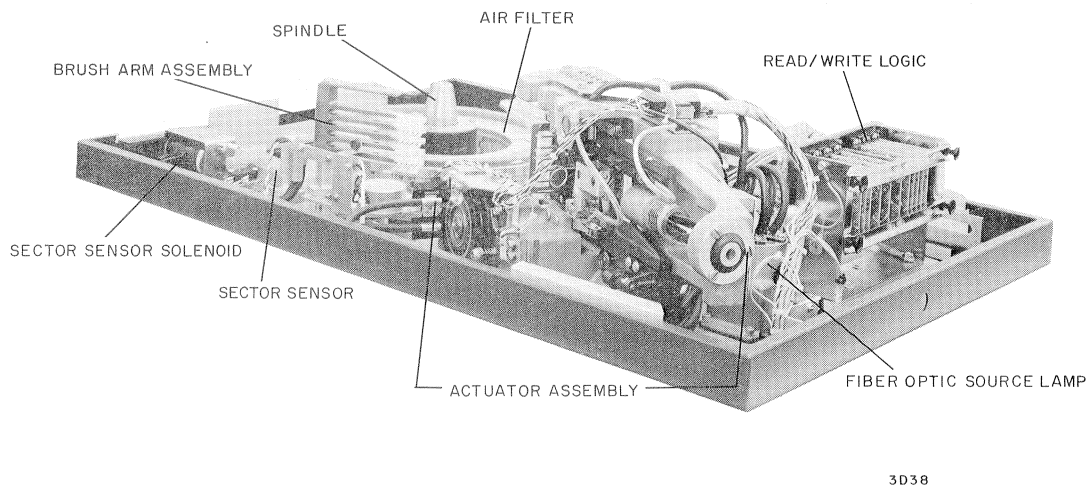

Figure 3-9. Actuator Assembly

Carriage Subassembly

The carriage subassembly (Figure 3-10) is the mounting point and the accessing mechanism for the read/write heads.

The carriage consists of a casting on which are mounted 10 head/arm assemblies, two guide plates, two clamp strips, five torsion arms, five torsion arm loading gears, the heads-loaded latch assembly, torsion rod, cam mechanism, and the carriage rack gear.

Carriage motion is derived via the carriage rack gear which is driven by the carriage drive and positioning subassembly. Total travel of the carriage is 3.3 inches, of which 1.3 inches are required to bring the carriage from the fully retracted position outward until the heads are over track 00 of the disk pack.

Each read/write head is mounted on a supporting arm to form a head/arm assembly, Figure 3-11. The 10 head/arm assemblies are secured to the carriage (using the guide plates and the clamping strips) in two equal adjacent vertical stacks.

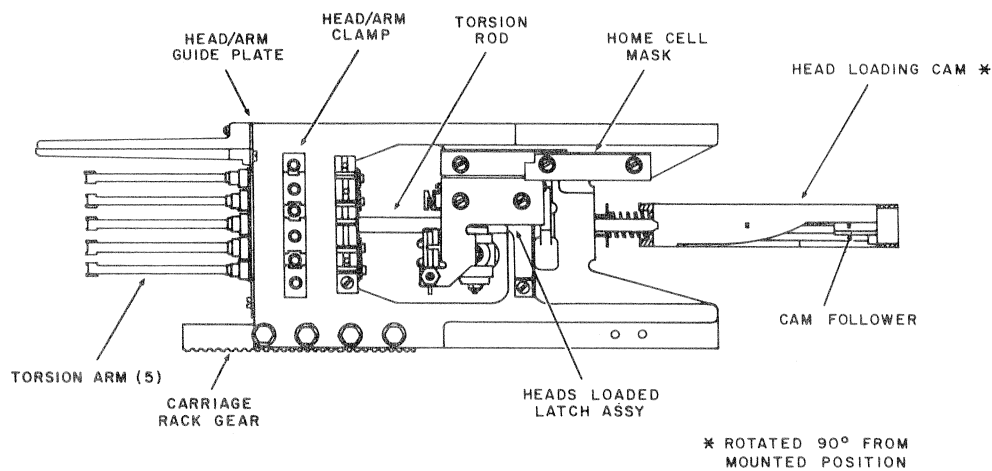

3020

Figure 3-10. Carriage Subassembly

The torsion arms, torsion arm loading gears, and the heads-loaded latch assembly are used during head loading and unloading operations. A torsion arm is secured to the center of each torsion arm loading gear. The five gears are mounted in line

vertically (between the two rows of heads) and are driven by the center gear. When the gears turn, the attached torsion arms rotate and each tip of the T-shaped torsion arms applies a vertical (either up or down) force to the back side of one head/arm assembly. This vertical force drives the head face toward the related disk surface. The spinning disk surface creates a cushion of air between itself and the adjacent head face. An equilibrium is established between the two forces so the head flies at approximately 120 microinches from the disk surface. The heads-loaded latch assembly holds the heads in the loaded position until power is removed from the spindle drive motor or the speed of the disk pack drops below a predetermined rpm. The cam mechanism and torsion rod are also used during read/write head loading and unloading operations. These operations involve additional components that are not part of the carriage sub-assembly. For a detailed description of the operation, refer to the Head Loading paragraph.

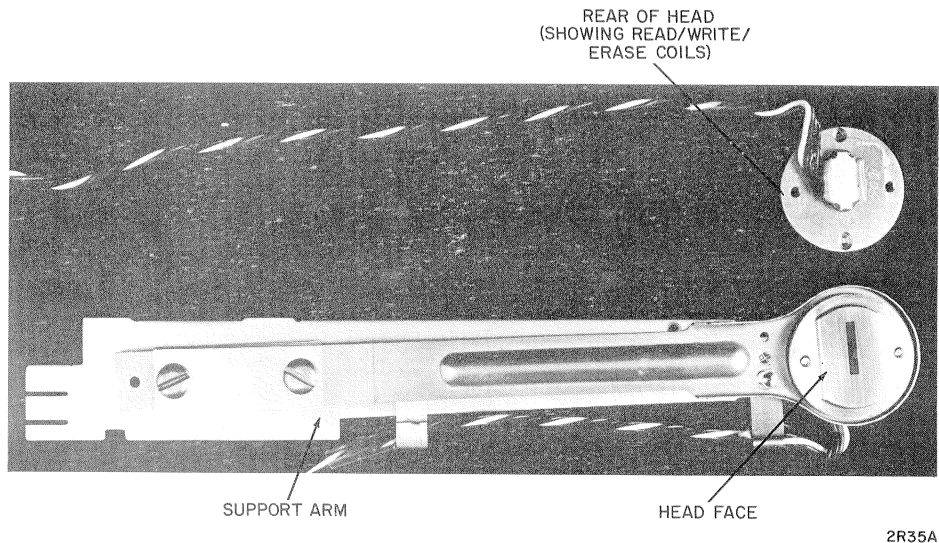

Figure 3-11. Head/Arm Assembly

Carriage Mount Subassembly

The carriage mount (Figure 3-12) is the mounting point for the carriage subassembly and the carriage drive and positioning mechanism. It consists of a casting, cantilevered and fixed bearings, shock mount, cam latch solenoid, and the home photocell assembly (home cell).

The cam latch solenoid is used during read/write head loading and unloading operations. These operations involve additional components that are not part of the carriage mount. For a detailed description of the operation, refer to the Head Loading paragraph.

The home cell consists of a fiber optic and a phototransistor mounted on a bracket which is secured to the carriage mount. When light from the fiber optic excites the phototransistor, the latter produces a signal. Mounted on the movable carriage sub-assembly is the home cell mask. The mask separates the fiber optic from the phototransistor when the read/write heads are positioned within the data track area. Whenever the heads are positioned outside of the data track area, the light from the fiber optic activates the phototransistor which sends a signal to the logic chassis. The logical response to the occurrence of a home cell signal depends on the operation being performed at the time.

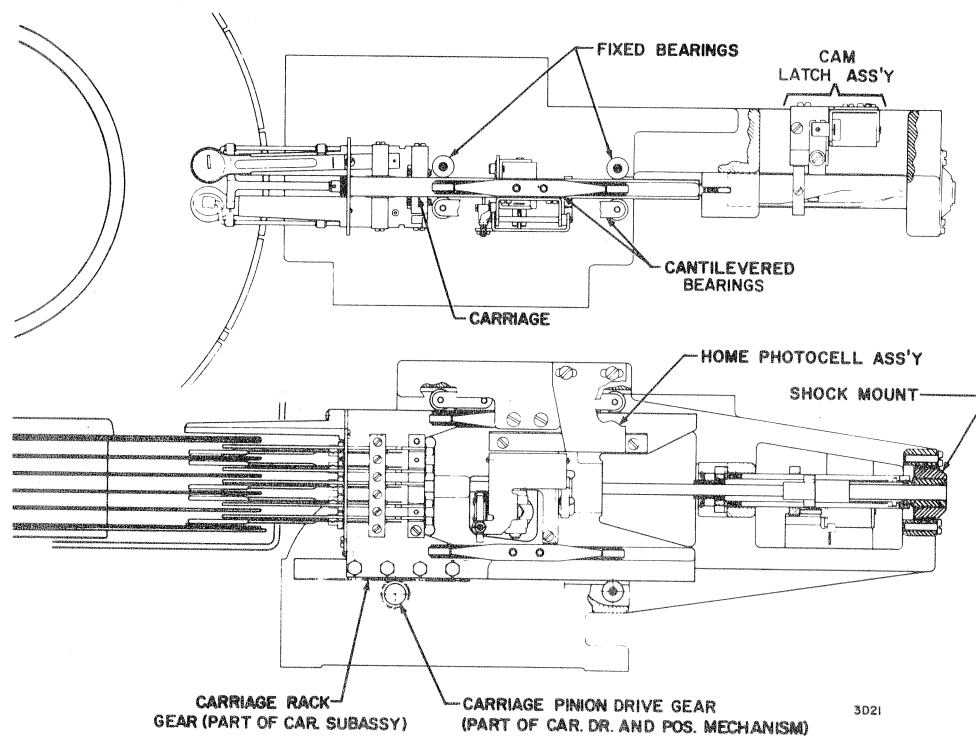

Figure 3-12. Elements of Carriage Mount Subassembly

The carriage mount casting is accurately positioned on the main deck by a dowel pin and is secured to the deck by four machine bolts. The carriage mount casting, in effect, surrounds the carriage subassembly with bearing surfaces. The carriage subassembly is supported from below by a fixed bearing (and the carriage pinion drive gear which engages the carriage rack gear). The carriage is held down on the bearing (and the gear) by cantilevered bearings at the top of the carriage. The carriage subassembly is also supported horizontally by three cantilevered bearings which are opposed by fixed bearings. The carriage may only be extended toward the disk pack or retracted from it.

Carriage Drive and Positioning Mechanism

The carriage drive and positioning mechanism (Figure 3-13) provides the mobility required by the carriage. The mechanism also keeps itself in check by providing velocity and position signals to the logic chassis. The logic decodes these signals and returns signals which cause the carriage to be driven to the desired track or cylinder at speeds that are proportional to the distance that must be traveled. When the read/write heads are positioned over the desired track, the carriage drive and positioning mechanism locks itself in place while the Read or Write operation takes place.

A move command comes from the controller. The command specifies the number of tracks to be moved (entered into the Decrement counter on logic chassis) and the direction of the move (relative to the disk storage drive's current position). When a move command is received from the controller, current is supplied to the detent solenoid. Activating the solenoid causes the spring-loaded pawl to be pulled out of the detent gear. The drive and positioning mechanism is now free to move.

The move command is applied to the printed circuit motor in the form of current. The polarity of the current determines the motor's direction of rotation. The amplitude and drive time of the applied current depends on the number of cylinders of data over, which the carriage must be moved. When the number of cylinders to go is greater than 64, maximum drive current is applied to the motor and no velocity limits are imposed.

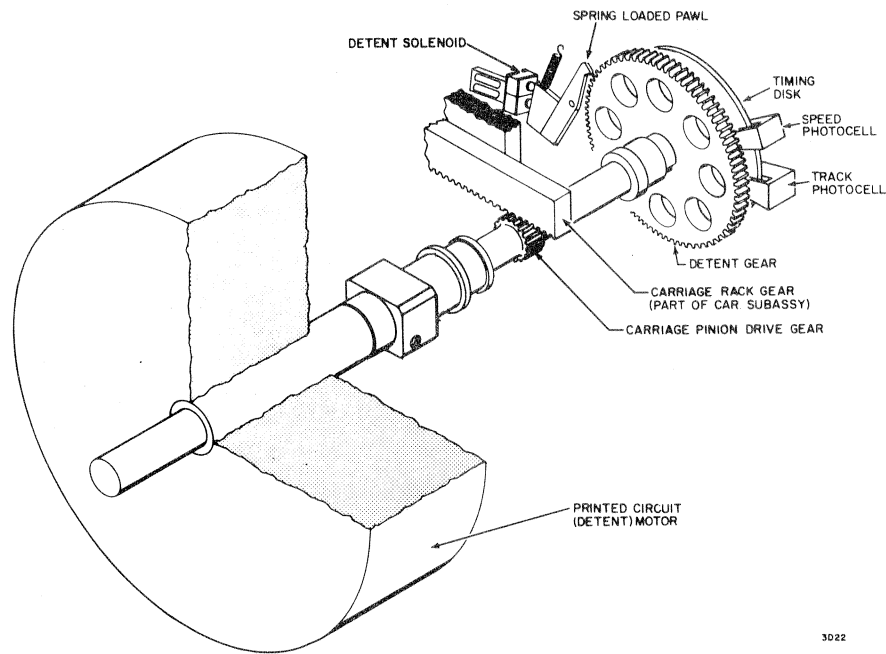

3022

Figure 3-13. Carriage Drive and Positioning Mechanism

As the motor is driven, the carriage pinion rotates giving forward or reverse movement to the carriage rack gear (Figure 3-14). As the carriage assembly moves, a corresponding rotational movement is imparted to the detent gear and the glass timing disk. A pair of photocells sense the slots etched on the timing disk as they pass.

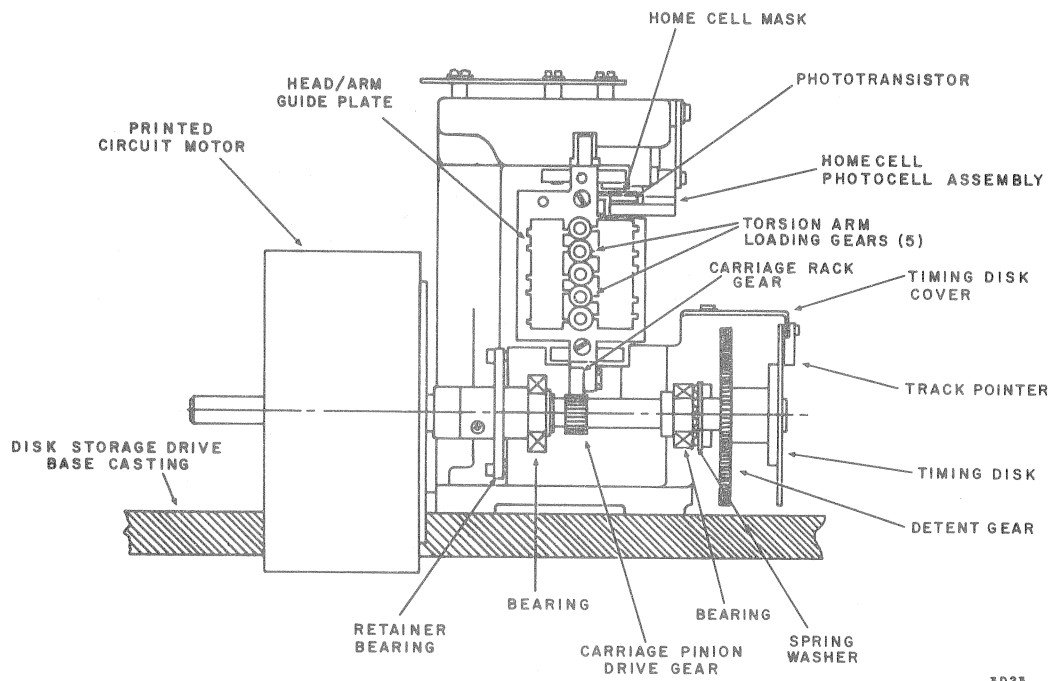
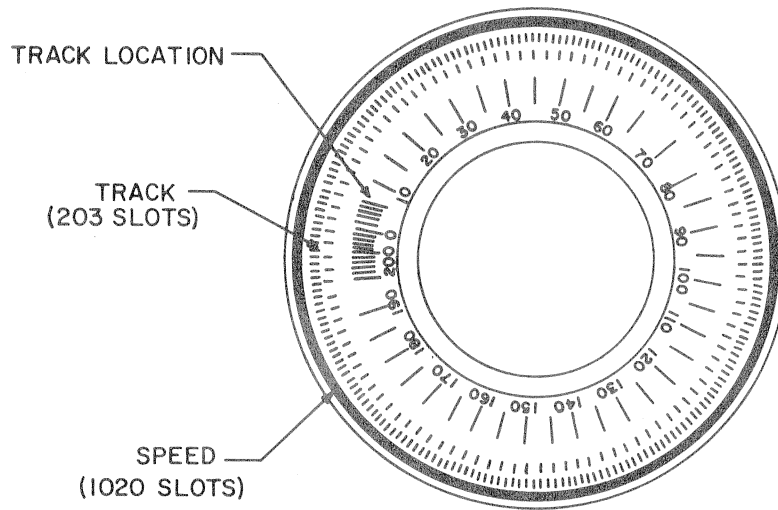

Figure 3-14. Front View Actuator Cutaway

This glass disk is photoetched with three concentric rings of transparent slots (Figure 3-15). The outer ring contains 1020 slots, the middle ring contains 203 slots, and the inner ring contains 100 slots. Only the outer and middle ring of slots are used by the disk storage drive. The middle ring (203 slots) represents the data cylinder (200 plus 3 spares) locations on the disk pack. Each slot corresponds to a gear tooth on the detent gear. The blank position provides an area used for reversing carriage motion. As the space between each slot (track) is crossed, the fiber optic light contacts the phototransistor and produces an output pulse to the logic chassis. Each output pulse decreases the content of the Decrement counter by one.

The outer ring (1020 slots) provides pulses that are used for speed control of the printed circuit motor. The output pulses of this ring are supplied to the logic where the time between the pulses is measured to determine the speed of the motor and hence the carriage. The greater number of slots is required for speed sensing to maintain stability at lower speeds.



3024

Figure 3-15. Timing Disk

The fourth ring of markings (numbered) on the disk, indicates the track number at which the carriage is located. The track location is read at the indicator index that overhangs the disk.

When a maximum carriage movement of 200 cylinders is required, full current is applied to the motor, accelerating the carriage at a maximum rate. The carriage continues to accelerate until the Decrement counter indicates less than 64 cylinders to go. At this time the carriage velocity is approximately 35 ips.

When the carriage has less than 64 cylinders to go, the current applied to the motor is reversed, dynamically braking the motion of the carriage to 15 ips. When the speed is reduced to 15 ips, the motor is servoed (current is applied to the motor in pulses so that the average current sustains the carriage at the selected speed). The servoing of the printed circuit motor continues until the Decrement counter indicates less than 16 cylinders remaining to the selected cylinder. At this point, the carriage is again dynamically braked. When the carriage has been slowed to 6 ips, the printed circuit motor is servoed until the Decrement counter indicates less than 4 cylinders remaining to the desired cylinder. The carriage is again dynamically braked, reducing the forward speed of the carriage to 2 ips. The carriage continues to be moved forward at 2 ips until the selected cylinder is reached.

When the trailing edge of the next to last track pulse is sensed, the Stop command is initiated within the logic. This command is not completed until the leading edge of the last track pulse is detected. The trailing edge of the last track pulse causes the logic to produce a Detent command. The Detent command drops the current to the detent solenoid. The detent pawl is spring-loaded so that when the solenoid is de-energized, the spring pulls the pawl to the detent gear. When the pawl engages the gear, it holds the carriage securely on the selected cylinder.

When the Detent command occurs and the pawl begins to drop, a delay is initiated. During this delay time, the gear continues to rotate so that the falling pawl is approximately one-third of the way over the selected gear tooth when the delay is timed out. The end of the delay causes a 2-ms high-current Dynamic Braking pulse to be applied to the motor. This pulse completely stops the motor (and the carriage) so that the pawl tip engages the gear very near to the center of the selected slot. Starting at the Detent command, a settling time of 10 ms is allowed for all vibration to be damped before an On Cylinder signal is sent to the controller. This signal indicates that the disk storage drive is ready for a Read or Write operation.

Head Loading

Head loading amounts to applying spring pressure to the back of the read/write head so the aerodynamically shaped head face approaches the related disk surface. When the cushion of air that exists on the surface of the spinning disk is encountered, it resists the further approach by the head. Spring pressure is designed to just equal the opposing cushion pressure (function of disk pack rpm) at a height of approximately 120 microinches. As a result the head flies. However, if the spring pressure exceeds the cushion pressure (as would happen if the disk pack lost enough speed), the heads will stop flying and contact the disk surface. This could cause damage to the head as well as the disk surface.

The read/write heads must be loaded to the disk surfaces before exchanging data with the controller. The heads must be released from this position (unloaded) and driven clear of the disk pack when power is removed to the unit or the disk pack velocity falls below a predetermined rpm. The actuator components involved in these operations are identified on Figure 3-16.

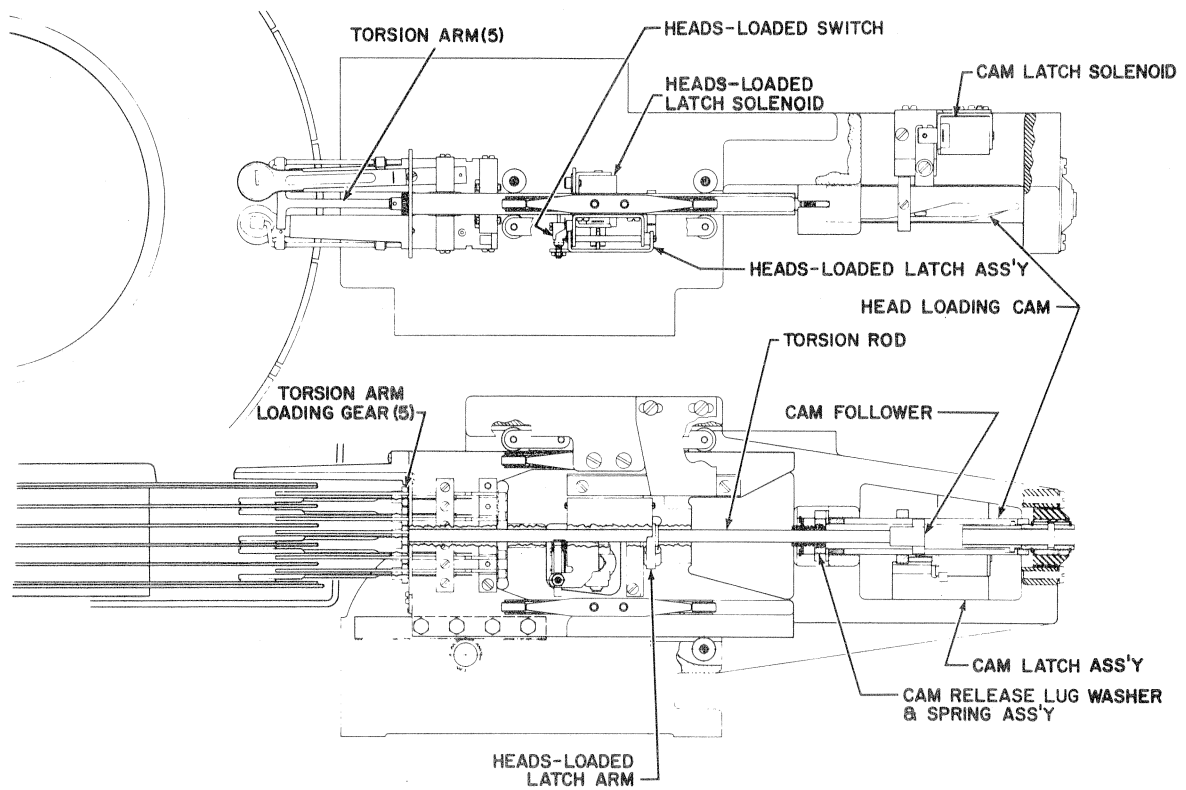

2R40A

Figure 3-16. Head Loading Components

When the unit is initially energized, the carriage subassembly is in the retracted position (heads clear of the disk pack edge) and the heads are unloaded. However, as the power to the unit is sequenced up, the disk pack speed is brought up to 2400 rpm. When the pack is up to 1900 rpm, a 52-second delay is allowed for the pack to purge the air in the shroud area and for the brush assembly to complete a clean cycle of the disk pack. This action assists in maintaining clean disk surfaces and reduces the possibility of disk scoring.

After the cleaning cycle is completed, the machine automatically proceeds to load the heads by performing a First Seek operation. First the spring-loaded pawl is pulled out of the detent gear by energizing the detent solenoid. When the pawl tip is out of the gear, the printed circuit motor starts driving the carriage toward the spindle at 6 ips.

With the heads unloaded, the torsion rod holds the cam follower at such an angle that the head loading cam is aligned with two notches in the carriage shock mount. The head loading cam is forced into these notches by the cam latch solenoid when the carriage starts moving forward.

With the head loading cam held (to stop rotation) by the notches, the cam follower is forced to ride the cam sides and rotates the torsion rod 60 degrees. Rotation occurs as the carriage is moved forward.

The 60-degree rotation imparted to the torsion rod by the cam follower turns the middle torsion arm loading gear. The five gears are meshed and mounted vertically so that as the middle gear rotates all the gears rotate (Figure 3-17).

A torsion arm mounted in the center of each gear is connected between each pair of heads. By rotating each arm, one head is forced down toward a disk surface while the other head is forced upward toward a disk surface. Rotating the five gears and torsion arms (each accommodating two heads) results in the loading of all ten heads. At the end of the 60-degree rotation, the heads are loaded and the heads-loaded latch arm engages a catch in the heads-loaded latch assembly. The catch is enabled by the latch solenoid when the pack is up to speed.

When the heads have been loaded, the heads-loaded switch closes and the head loading cam is disengaged by de-energizing the cam latch solenoid. The heads remain loaded as long as the heads-loaded latch solenoid is energized. If power to the machine is lost or the disk pack speed is not properly maintained, the solenoid is de-energized.

This releases the latch arm and removes torsion arm pressure to the back side of the heads causing the heads to move (vertically) away from the disk surfaces. An air damper device cushions the release of the heads.

When the heads are loaded, the First Seek operation generates a Reverse Motion command. This causes the carriage to be driven in the reverse direction at 6 ips. The carriage is retracted until a home cell signal is sensed at which time a Forward Motion command occurs, causing the carriage to be driven forward at 2 ips to cylinder 00 where the spring-loaded pawl is dropped.

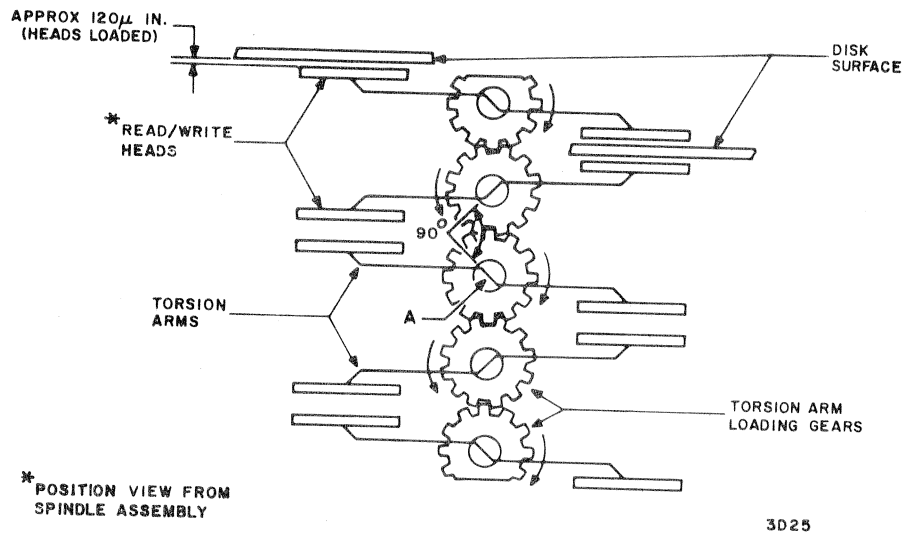

Figure 3-17. Head Loading Mechanism

CABINET COOLING

Filtered air is distributed throughout the disk storage drive to clean and cool the various components (Figure 3-18).

The logic chassis is cooled by filtered air from two fans. The front panel of the unit allows air to enter between the lower position of the panel and the main frame. Mounted over this opening is the logic chassis air intake through which air is drawn, filtered, and then forced upward between the cards of the logic chassis. The warm air is exhausted through openings in the top of the logic chassis and channeled out of the disk storage drive between the top of the front panel and the main frame and the grill in the front panel.

The power supply is also cooled by filtered air from two fans. Air enters between the lower portion of the rear panel and the main frame. This air is drawn along the bottom of and to the rear of the power supply by the fans. The air is then forced through the power supply, exhausted through a grill in the top of the power supply, and channeled out (via a metal deflector) through the openings between the top of the rear panel and the main casting and the rear panel grill.

The spinning disk pack acts as an air pump, drawing air through the filter at the base of the disk pack on the main deck and through the nylon mesh filter in the base of the disk pack. This air is channeled up through the hub of the disk pack and dispersed outward between the disks. Consequently, all air in and around the disk pack surfaces is filtered air. This prevents head and disk surface damage due to foreign particle accumulation. Whenever the disk pack is set in motion, a 52-second purge time (starting when disk pack is up to 80 percent of maximum speed) is allowed to clean the disk surfaces before the heads are loaded. The filtered air blown across the disk surfaces is forced through the shroud opening for the head/arm assembly. The air is exhausted through an opening between the lower edge of the top rear cover and the main frame and through slotted holes at the back of the top rear cover.

DISK PACK ASSEMBLY

The disk pack is the recording medium for the disk storage drive. The disk pack consists of six 14-inch, magnetic-oxide coated disks that are center-mounted on a vertical shaft. Eight recording surfaces are gained by using both surfaces of the four interior disks. Only the inner (relative to original four) surfaces of the top and bottom disk are used; yielding a total of 10 recording surfaces. The outer surface

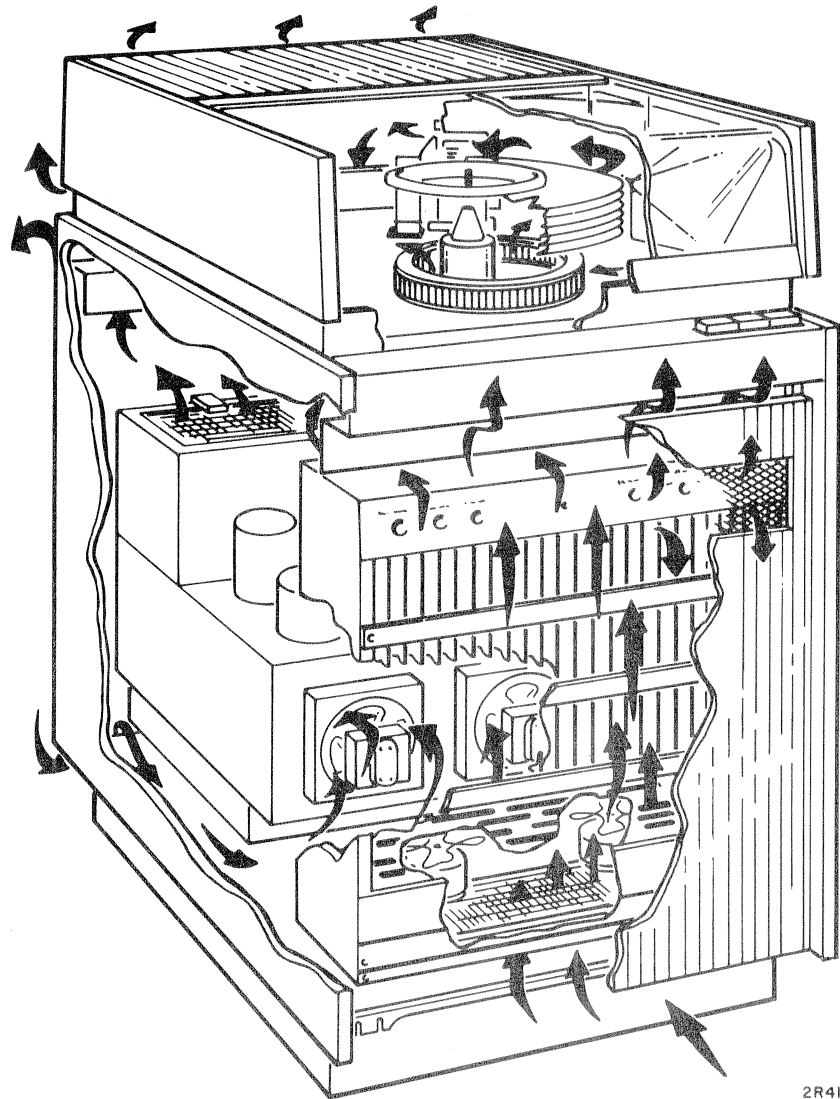

2R41A

Figure 3-18. Cabinet Cooling

of the top recording disk is covered by a seventh disk which provides stability and protection only. A larger disk at the bottom of the assembly with notches around the circumference, divides the disk pack into organizational pieces called sectors.

The disk pack mounts on and is driven by the spindle of the disk storage drive. Each disk pack has a two-piece dust cover (plastic cannister with bottom). The handle

of the plastic cannister contains a mechanism to release or lock (depending on direction of rotation) the disk pack on the spindle during removal or installation.

When the disk pack is not installed, both dust covers should be in place. After the disk pack is installed, the plexiglass cover of the disk storage drive should be kept closed.

DATA RECORDING

CYLINDER CONCEPT

The 10 recording surfaces of a disk pack are numbered 00 through 09 from top to bottom. Ten read/write heads are mounted on the carriage assembly in two equal, adjacent, vertical stacks. Each head is oriented so as to service one disk surface. Each head is identified by the number assigned to the disk surface it services. By moving the carriage assembly, the actuator can position the 10 heads (as a group) at 200 discrete positions (tracks) on the disk surfaces. These 200 tracks are numbered 00 through 199 from the outer edge of the disk pack toward the spindle. Assume now that the disk pack is rotating and that the actuator is detented so that the heads are positioned over track 50 of the disk surfaces. Then a cylinder (Figure 3-19) is defined as the total data available to all heads during one revolution of the disk pack. In this example there would be 149 additional cylinders of data available if the heads were moved one track at a time toward the spindle (forward), and 50 additional cylinders if the heads were moved in the reverse direction from their present position.

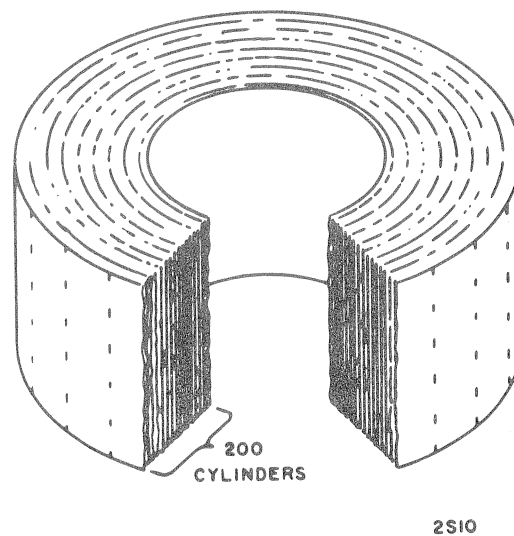

Figure 3-19. Cylinder Concept

SECTION 4

INTERFACE

INTERFACE

SYSTEM CABLING

The disk storage drive units are designed so that eight units may be connected to each controller. The cabling required to accomplish this intercabling is shown in Figure 4-1.

The cabling arrangement shown for cable A is called "daisy chaining". Signals in this cable are coupled through intervening units during exchanges between the controller and the active disk storage drive.

Voltages and signals of cable B are exchanged directly between the controller and the active unit, and are not termed "daisy chaining".

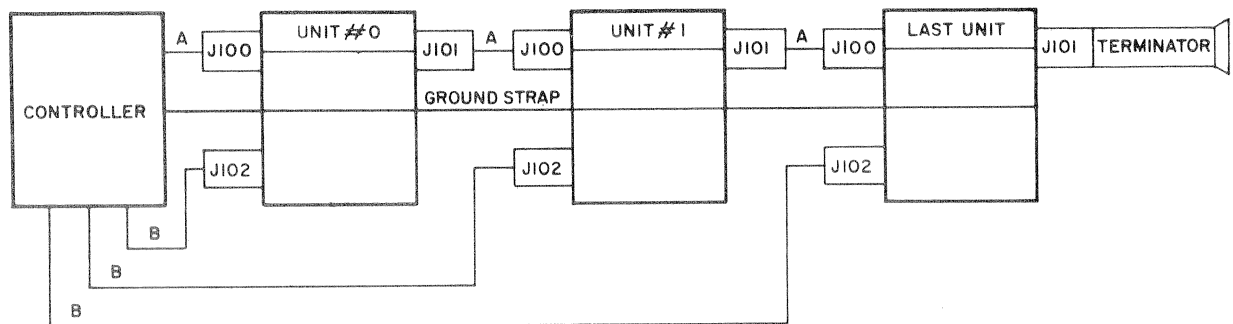

NOTES:

A— DATA AND CONTROL CABLE

B— SEQUENCE PICK AND HOLD, UNIT SELECT, UNIT SELECTED, LINE TERMINATION SUPPLY.

6J4

Figure 4-1. System Intercabling Diagram (Daisy Chain)

To effect system operation, each machine must be plugged into the primary power sources, and the MAIN POWER and DC INPUT POWER circuit breakers at each unit must be set to ON. If any one of the machines is not plugged in or one of the circuit breakers is OFF, subsequent machines cannot be cycled up or used (Figure 4-2).

CAUTION

Do not turn the power supply MAIN POWER or DC INPUT POWER circuit breakers of an inactive disk storage drive on or off while another storage drive is reading or writing. This may produce errors to the controller or to the disk storage drive recording surface.

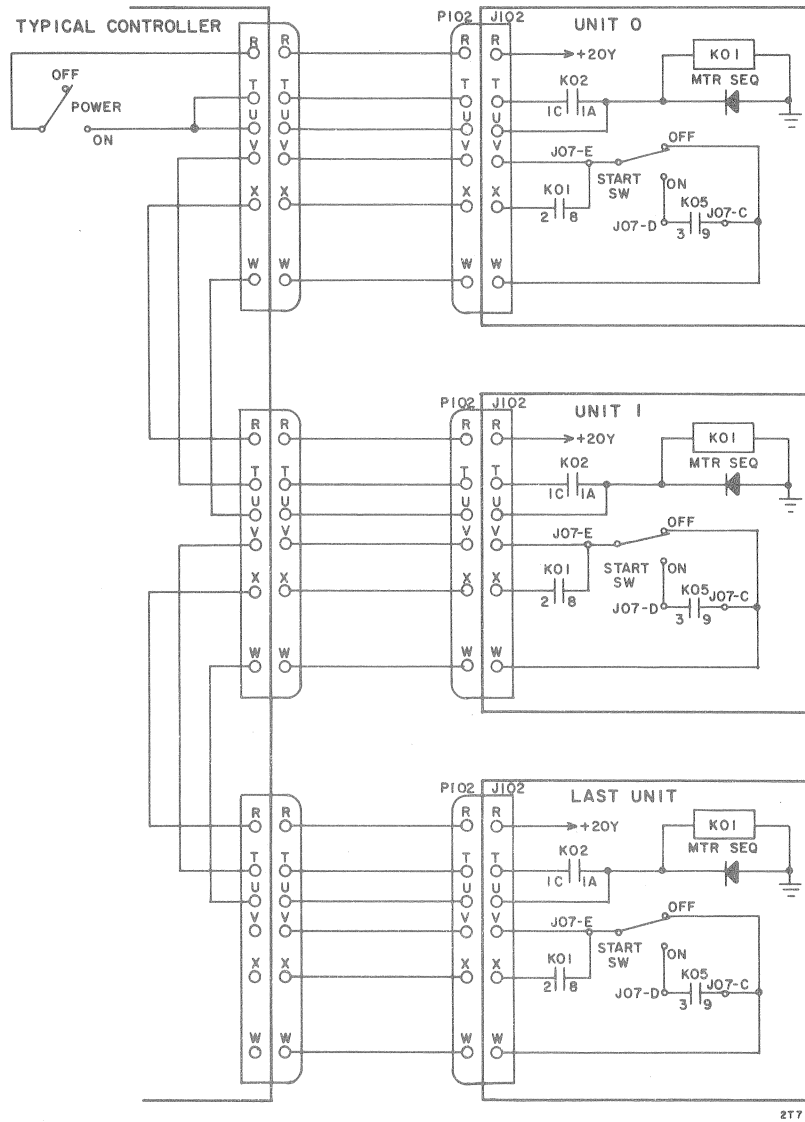

Figure 4-2. System Power-On Sequencing Circuit

SECTION 5

PREVENTIVE MAINTENANCE

PREVENTIVE MAINTENANCE

GENERAL

The performance of the disk storage drive depends on a carefully planned and executed program of preventive maintenance and proper corrective maintenance when required. This program, if followed, will ensure optimum performance and maximum up-time.

MAINTENANCE PRECAUTIONS

The air is kept clean and any loose dust is evacuated when pressurization of the pack and actuator area is positive. Dust does not accumulate under these conditions. However, when the disk storage drive is off or a disk pack is in storage, dust and dirt accumulates on the heads and the recording surfaces. This can cause scoring of the heads and recording surfaces when the heads are loaded.

Therefore, do not leave a disk pack on an unpowered unit and secure the bottom cover immediately upon removal from the disk storage drive. Leave the cover secured until the disk pack is again mounted on the spindle. Clean both the top and bottom cover periodically so that they do not become a source of contamination.

HEAD REPLACEMENT CRITERIA

The read/write heads have been designed so that they should not need to be replaced if given proper preventive maintenance and care. If a head requires replacement, refer to Section 6 of this manual. Heads are defective and need replacing if any of the following conditions exist:

1. Consistent oxide buildup on the head, indicating repeated head/disk impact.
2. Concentric scratches on the disk surface. Inspect the head for imbedded particles.
3. An audible ping indicating that the head is hitting the disk surface.

DISK PACK REPLACEMENT CRITERIA

The disk pack has been designed to last the lifetime of the equipment. Replacement of the disk pack is required only if excessive runout (see Disk Pack Runout Check, Section 7) is encountered or physical damage to the pack results in the loss of recording ability. This physical damage includes:

1. Damage to the disk pack resulting in a broken disk. If a disk is bent, refer to Disk Pack Runout Check, Section 7.
2. Gouged or scored disk surface causing the loss of data.
3. Imbedded particles in a disk surface that cannot be removed by cleaning and are causing damage to the heads.

PREVENTIVE MAINTENANCE INDEX

There are three levels of maintenance in the preventive maintenance schedule. These are based on a calander period or hours used (whichever comes first). An elapsed time meter, located on the power supply, keeps a cumulative record of operating time.

The preventive maintenance procedures, referenced in the Preventive Maintenance Index (Table 5-1), follow the index and are in numerical order. The three levels of maintenance listed in the index are as follows:

- Level 1 - Weekly or 150 hours
- Level 2 - Monthly or 500 hours
- Level 3 - Quarterly or 1500 hours

TABLE 5-1. PREVENTIVE MAINTENANCE INDEX

Level	Code	Procedure	Page
1	PM-1006	Clean read/write heads	5-4
1	PM-1011	Clean plexiglass cover	5-5
1	PM-1015	Clean shroud and spindle	5-6
1	PM-1020	Check for head crashing	5-7
1	PM-1025	Run diagnostic test	5-8
2	PM-1030	Clean cabinet	5-9
2	PM-1031	Inspect brushes	5-10
2	PM-1035	Replace air intake filters	5-11
2	PM-1040	Lubricate rack, pinion gear, and cam	5-12
2	PM-1045	Lubricate detent gear	5-13
2	PM-1046	Lubricate detent pawl	5-14
2	PM-1050	Lubricate cam release lug washer	5-15
2	PM-1055	Lubricate carriage rollerways	5-16
2	PM-1060	Lubricate torsion arm loading gears	5-17
2	PM-1065	Lubricate disk pack locking screw and spindle lockshaft	5-18
2	PM-1073	Check power supply voltages	5-19
2	PM-1076	Check phototransistor outputs	5-20
3	PM-1080	Replace shroud filter	5-23
3	PM-1087	Check carriage limit stop	5-24
3	PM-1090	Check compatability	5-25
*	PM-2006	Inspect disk pack	5-27
*	PM-2011	Clean disk pack	5-28
*	PM-2016	Check disk pack filter	5-29
*As required			

PREVENTIVE MAINTENANCE PROCEDURE

PM-1006

CLEAN READ/WRITE HEADS

1. Place MAIN POWER and DC INPUT circuit breakers in OFF position.
2. Remove disk pack from spindle.
3. Raise top cover and manually move carriage to forward limit. Close top cover.
4. Raise front cover.
5. Wrap head cleaning tool (84323000) or wooden paddle with No. 1 tube gauze (12209713).
6. Using alcohol dispenser (12211578), dampen loaded cleaning tool with isopropyl alcohol (12210956).

CAUTION

Do not touch or breathe on heads; skin acids etch head surfaces and moisture causes dust to accumulate and rust to form. Wipe heads carefully; residue or dirt scores heads and disks when unit is returned to operation.

7. Support back of head being cleaned with a second paddle.
8. Thoroughly wipe face of each head with dampened cleaning tool.
9. Inspect head surface with a dental mirror.

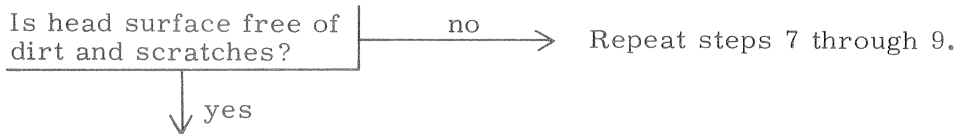

10. Manually move carriage to retract position.

PREVENTIVE MAINTENANCE PROCEDURE

PM-1011

CLEAN PLEXIGLASS COVER

1. Remove disk pack from spindle.

CAUTION

Use a liquid detergent and water solution to clean the Plexiglass cover. All other cleaning agents may damage the Plexiglass surface.

2. Dust cover lightly, then wash with liquid detergent and water.

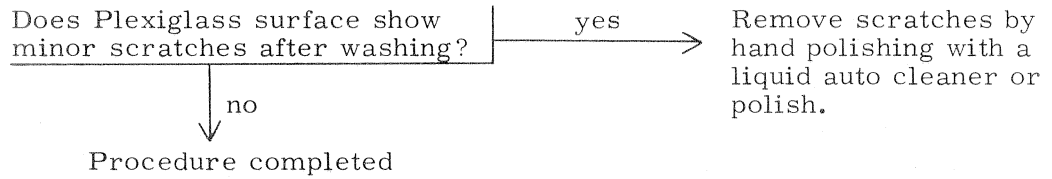

PREVENTIVE MAINTENANCE PROCEDURE

PM-1015

CLEAN SHROUD AND SPINDLE

1. Raise and latch top cover.
2. Remove disk pack from spindle.
3. Dampen a lint-free cloth or Kimwipe with isopropyl alcohol (12210956).
4. Wipe shroud and spindle carefully. Remove all dirt and smudges.
5. Inspect shroud area.

Are there any metal or dust particles on or around shroud?

yes

Using sticky surfaces of adhesive or masking tape, remove all loose particles from shroud area.

no

Procedure completed

PREVENTIVE MAINTENANCE PROCEDURE

PM-1020

CHECK FOR HEAD CRASHING

1. Mount a disk pack on spindle.
2. Raise and latch top cover and bypass interlock.
3. Press (to light) START switch and allow heads to load.
4. Manually disengage detent pawl.
5. Move carriage assembly slowly back and forth across disk surfaces.
Listen for audible ping or scratching noise caused by heads contacting disk surface.

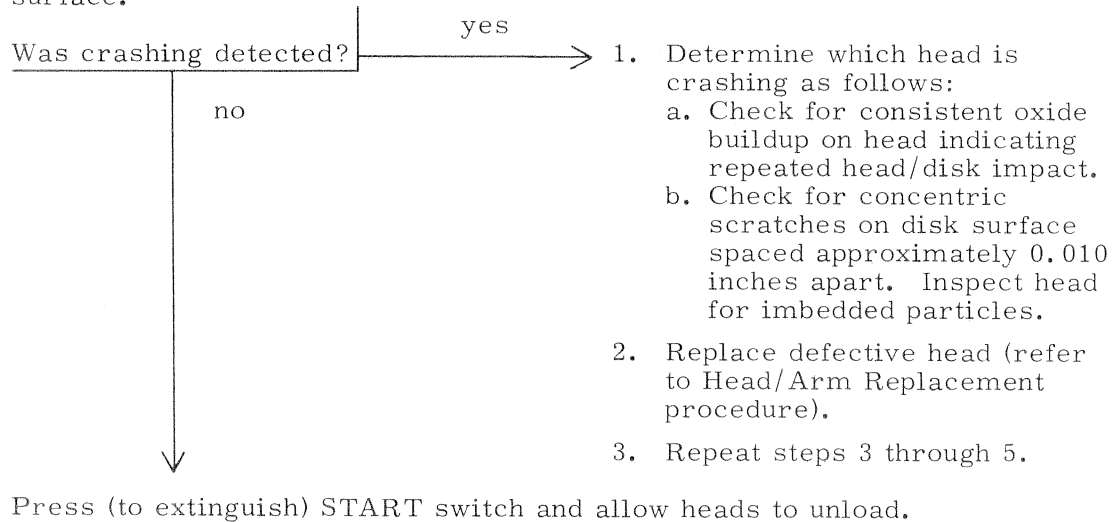

PREVENTIVE MAINTENANCE PROCEDURE

PM-1025

RUN DIAGNOSTIC TEST

1. Mount a scratch disk pack on spindle (information on pack will be destroyed).
2. Press START switch and allow heads to load.
3. Run applicable diagnostic test.

Were any errors detected?

yes →

1. Troubleshoot and correct problem.
2. Repeat step 3.

no ↓

Procedure completed

PREVENTIVE MAINTENANCE PROCEDURE

PM-1030

CLEAN CABINET

1. Raise and latch top cover.
2. Open front panel and swing out logic chassis.
3. Using a vacuum cleaner, thoroughly clean entire main deck area and inside of cabinet.

PREVENTIVE MAINTENANCE PROCEDURE

PM-1031

INSPECT BRUSHES

1. Raise and latch top cover.
2. Inspect brush assembly and inner shroud area for accumulation of loose particles.

Was any evidence of oxide
or foreign material found?

yes

1. Remove contaminated brushes by gently snapping brush out of brush holder.
2. Align flat of replacement brush with key of brush holder and insert into place.
3. Perform procedure PM-1015.

no

Procedure completed

PREVENTIVE MAINTENANCE PROCEDURE

PM-1035

REPLACE AIR INTAKE FILTERS

1. Open front panel and swing out logic chassis.
2. Remove air filter from bottom of logic chassis and replace with new filter.
3. Open rear panel and slide out power supply.
4. Remove air filter from rear of power supply and replace with new filter.

PREVENTIVE MAINTENANCE PROCEDURE

PM-1040

LUBRICATE RACK, PINION GEARS, AND CAM

1. Raise and latch top cover.
2. Manually disengage detent pawl and move carriage to forward limit.
3. Add 2 drops of oil (12208888) to each of four oil wick assembly holes on carriage drive rack.
4. Add 1 drop of oil to pinion.
5. Add 1 drop of oil to upper and lower forward sloping surface of head loading cam.
6. Manually move carriage to retract position.

PREVENTIVE MAINTENANCE PROCEDURE

PM-1045

LUBRICATE DETENT GEAR

1. Remove detent pawl spring and disengage pawl.
2. Carefully clean detent gear with a lint-free cloth or Kimwipe.
3. Apply a thin coat of oil (12208888) to detent gear.
4. Replace detent pawl spring.

PREVENTIVE MAINTENANCE PROCEDURE

PM-1046

LUBRICATE DETENT PAWL

1. Disconnect the pawl spring.
2. Remove self-locking nut, spring, and washers securing detent pawl.
3. Carefully clean the detent pawl with a lint-free cloth.
4. Fill grease well of detent pawl, coat bearing hole, and adjacent sides on detent pawl with Molykote, type G (95016101).
5. Install pawl.
6. Connect detent pawl spring.

PREVENTIVE MAINTENANCE PROCEDURE

PM-1050

LUBRICATE CAM RELEASE LUG WASHER

1. Disengage detent pawl.
2. Manually move carriage to forward limit.
3. Using a hypodermic syringe (or equivalent), carefully lubricate two cams on cam follower side of cam release lug washer with 1 drop of oil (12208888).
4. Move carriage to retract position.

PREVENTIVE MAINTENANCE PROCEDURE

PM-1055

LUBRICATE CARRIAGE ROLLERWAYS

1. Raise and latch top cover.
2. Carefully clean carriage rollerways with a lint-free cloth or Kimwipe.
3. Apply a thin coat of oil (12208888) to carriage rollerways.
4. Wipe off excess oil.

PREVENTIVE MAINTENANCE PROCEDURE

PM-1060

LUBRICATE TORSION ARM LOADING GEARS

1. Raise and latch top cover.
2. Apply 1 drop of oil (12208888) to each torsion arm loading gear.

PREVENTIVE MAINTENANCE PROCEDURE

PM-1065

LUBRICATE DISK PACK LOCKING SCREW AND SPINDLE LOCKSHAFT

1. Remove disk pack from spindle.
2. Using a lint-free cloth, wipe disk pack locking screw (in disk pack) and spindle lockshaft (in spindle) to remove contaminated lubricant. Repeat until surfaces are clean.
3. Apply a light coat of oil (12208888) to clean surfaces.

PREVENTIVE MAINTENANCE PROCEDURE

PM-1073

CHECK POWER SUPPLY VOLTAGES

1. Raise and latch top cover.

NOTE

Record all readings obtained during this procedure.

2. Measure $\pm 20V$ levels at pins 13 and 15 of buggie at location X16.

Do levels read 20V ($\pm 1V$)?

no \longrightarrow Adjust R03 (+) and R04 (-)
in power supply to obtain
proper readings.

yes



Procedure completed

PREVENTIVE MAINTENANCE PROCEDURE

PM-1076

CHECK PHOTOTRANSISTOR OUTPUTS

1. Raise and latch top cover.
2. Connect oscilloscope probe to output of home cell.
3. Manually move carriage to obtain maximum voltage output from photo transistor.

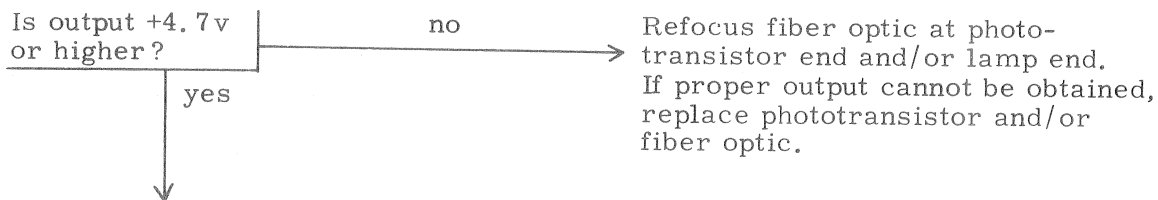

4. Check for following readings at indicated carriage positions:

TRACK	READING
-1	+3.0 to 6.0v
0	-0.7v (±0.2v)
202	-0.7v (±0.2v)
202 + 1	+3.0 to 6.0v

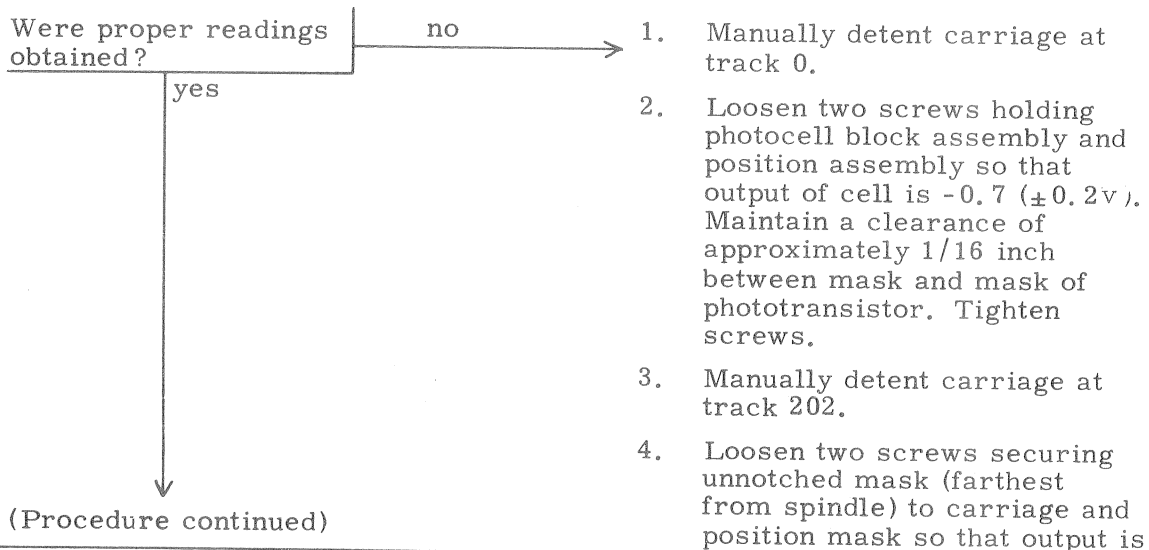

PREVENTIVE MAINTENANCE PROCEDURE

PM-1076 (Cont'd)

-0.7v ($\pm 0.2v$). Maintain a clearance of approximately 1/16 inch between mask and mask of phototransistor. Tighten screws.

5. Repeat step 4 of procedure.

5. Connect oscilloscope probe to output of speed cell.

6. Disengage detent pawl and observe output signal while slowly moving carriage back and forth.

Is maximum amplitude
above +4.7?

no

yes

1. Loosen two screws securing photocell assembly to photocell mounting plate.
2. Reposition photocell radially to obtain maximum amplitude. Make sure photocell is sensing outer row of slots on timing disk. Tighten screws.
3. Adjust phototransistor end of fiber optic and/or lamp end to obtain maximum amplitude. Maintain $6/32$ ($\pm 1/32$) inch clearance between fiber optic and timing disk.
4. If proper amplitude is not obtained, replace fiber optic and/or phototransistor.
5. Repeat step 6 of procedure.

7. Connect oscilloscope probe to output of track cell.

8. Disengage detent pawl and observe output signal while slowly moving carriage back and forth.

(Procedure continued)

PREVENTIVE MAINTENANCE PROCEDURE

PM-1076 (Cont'd)

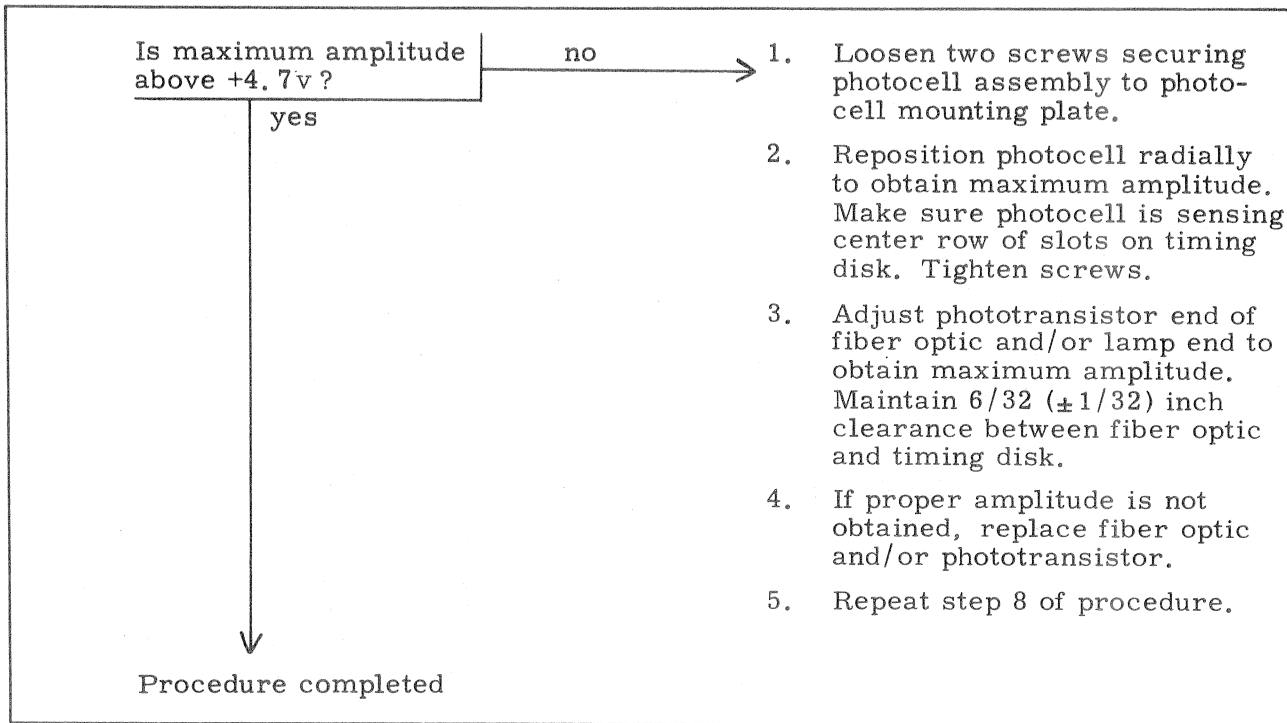

PREVENTIVE MAINTENANCE PROCEDURE

PM-1080

REPLACE SHROUD FILTER

1. Remove disk pack from spindle.
2. Raise and latch top cover.
3. Remove four screws securing shroud to top deck assembly.
4. Replace filter cartridge.
5. Reinstall shroud.

PREVENTIVE MAINTENANCE PROCEDURE

PM- 1087

CHECK CARRIAGE LIMIT STOP

1. Remove disk pack from spindle.
2. Remove and latch top cover.
3. Manually position carriage to track 100.
4. Using a feeler gauge, check that gap between bottom of delrin block and top of carriage is between 0.001 and 0.004 inch.

Was gap dimension correct? | no → Adjust setscrew located above delrin block to obtain correct gap dimension.

yes

5. Move carriage to retract position.

PREVENTIVE MAINTENANCE PROCEDURE

PM-1090

CHECK COMPATABILITY

NOTE

This procedure is only applicable to systems with two or more disk storage drives. On a one-unit system, perform the Head/Arm Alignment procedure at this time. Make sure that the diagnostic test (PM-1025) has been run on all units before performing this procedure.

1. Mount a scratch disk pack on unit 0.
2. Write headers on disk pack.
3. Run applicable diagnostic random positioning test.

CAUTION

If adjustments are made during this procedure, data previously written on disk packs may be lost.

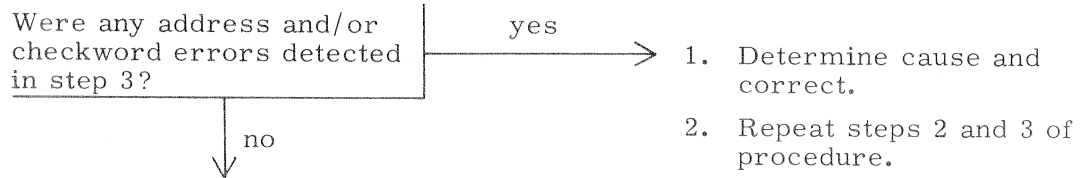

4. Move disk pack to next unit.
5. Without rewriting headers, run applicable diagnostic random positioning test.

(Procedure continued)

PREVENTIVE MAINTENANCE PROCEDURE

PM-1090 (Cont'd)

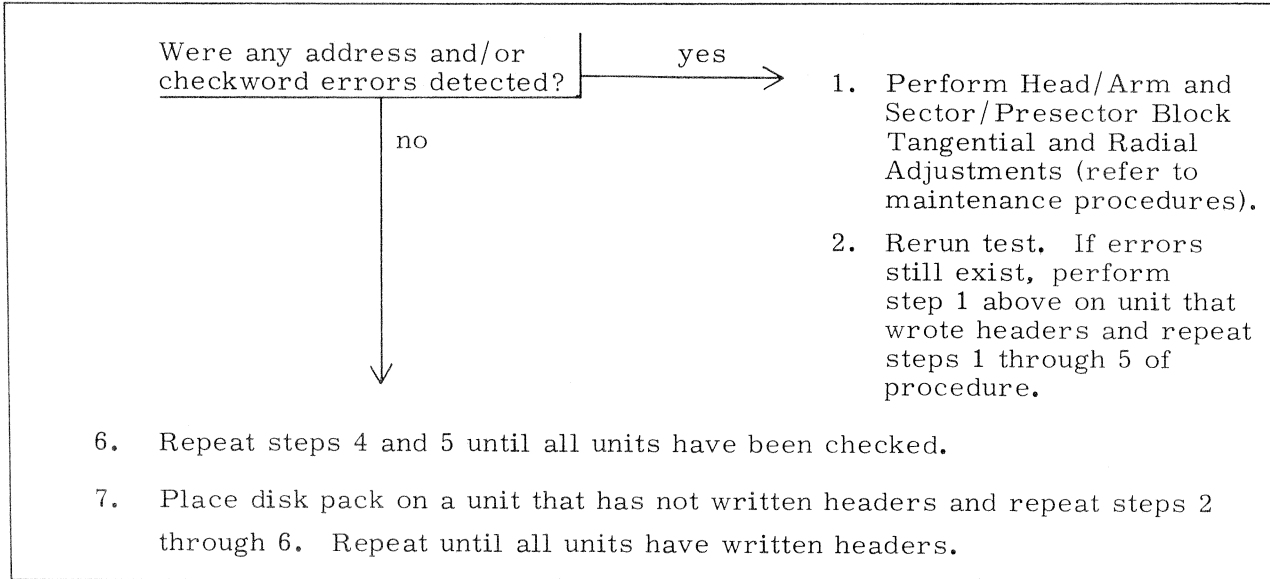

PREVENTIVE MAINTENANCE PROCEDURE

PM-2006

INSPECT DISK PACK

1. Place MAIN POWER circuit breaker in OFF position.
2. Raise front cover.
3. Inspect disk surfaces for scratches by rotating disk pack and shining flash-light between disks.

NOTE

Comet-like scratches indicate that a particle has been caught and dragged between the head and the disk surface. The particle is usually imbedded in the disk. Scratches that are concentric and have spirals connecting them indicate that the head contains an imbedded particle, has a burr on the shoe face, or is improperly mounted. Check the head related to that disk surface.

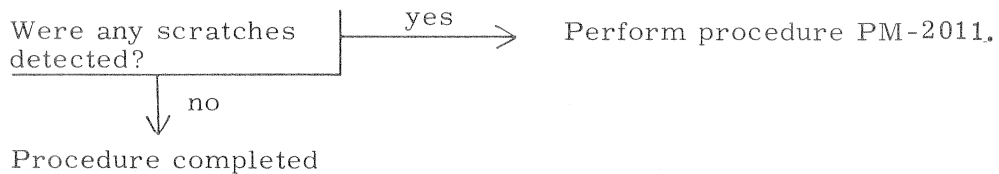

PREVENTIVE MAINTENANCE PROCEDURE

PM-2011

CLEAN DISK PACK

NOTE

The following guidelines should be used to determine the frequency of cleaning a disk pack:

- New disk pack; clean before using.
- Disk pack used less than once a week; clean before each use.
- Disk pack used more than once a week; clean once a week.
- Disk pack operating in other than clean computer room environment or involved in frequent start/stop operation; clean daily.
- Disk pack causing read errors; clean immediately.

1. Position Spindle Lock Disable switch to OFF.
2. Mount disk pack to be cleaned on spindle.
3. Wrap fiberglass spatula (84323000) or wooden tongue depressor with No. 1 tube gauze (12209713).
4. Using alcohol dispenser (12211578), dampen cloth with isopropyl alcohol (12210956).
5. Insert spatula between disks and manually rotate disk pack. Apply downward pressure to clean lower disk surfaces and upward pressure to clean upper disk surfaces. Withdraw spatula while disk pack is still rotating.
6. Wrap spatula with dry cloth and repeat step 5.
7. Dampen another spatula wrapped in lint-free cloth with isopropyl alcohol and wipe external surface of disk pack.

PREVENTIVE MAINTENANCE PROCEDURE

PM-2016

CHECK DISK PACK FILTER

1. Place MAIN POWER and DC INPUT POWER circuit breakers in ON position.
2. Remove disk pack from spindle.
3. Inspect nylon filter on bottom of disk pack.

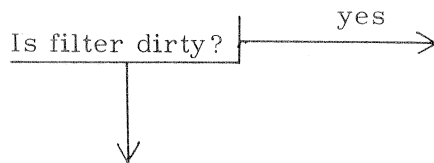

1. Remove rubber O-ring securing filter and remove filter.
2. Install a new filter (45546500) and secure with O-ring.

4. Mount disk pack on spindle.

SECTION 6

MAINTENANCE PROCEDURES

MAINTENANCE PROCEDURES

GENERAL

The maintenance procedures for the disk storage drive are provided in the form of replacement and adjustment procedures. It is recommended that maintenance personnel read the entire procedure prior to performing the replacement or adjustment.

In order to apply spindle drive motor power when the disk storage drive is disconnected from the controller, a jumper must be installed between pins R and U of connector J102 (located on connector panel at rear of logic chassis).

Refer to Section 1, Special Tools for a list of special tools required during the performance of maintenance procedures.

CAUTION

During some of the procedures of this section, it is necessary to operate the disk storage drive (disk pack installed) with the top covers open. Operating in this configuration for a period of 1 hour necessitates cleaning the heads and disk pack according to Section 5. Operating in this configuration for a period in excess of 2 hours may damage the read/write heads and disk pack.

REPLACEMENT

SPINDLE LOCK OR DRIVE BELT REPLACEMENT (Figure 6-1)

1. Press (to extinguish) the START switch. Disconnect the line voltage power cord.
2. Open and latch the disk drive top rear cover and remove the front panel. Swing the logic chassis out.
3. Proceed to step 4 for spindle lock replacement or step 5 for drive belt replacement.

4. Replace the spindle lock disk according to step a. Replace any other spindle lock part according to steps b, c, and d.
 - a. To replace the spindle lock disk, remove the two socket head screws securing the switch mounting bracket to the base of the spindle assembly. Carefully lower the assembly clear of the spindle. Remove the three screws and washers securing the spindle lock disk to the bottom of the pulley. Install the replacement disk with the original three screws and washers. Install the switch mounting bracket with two socket head screws. Use two washers between the bracket and the spindle casting leg at the right hand end of bracket (use one washer between the left-hand screw and the bracket). Secure the loose end of the ground cable with the screw in the right-hand end of the bracket. Proceed to step 6.
 - b. To replace the spindle lock solenoid, the pawl, or the spindle lock switch, tag and then disconnect the four electrical connections to the spindle lock assembly. Remove the two socket head screws that secure the assembly to the base of the spindle. Slide the assembly clear of the spindle. Replace the faulty component according to the original installation.
 - c. Tighten the screw/nut pivot through the pawl until all play is removed, but make certain that the pawl is free to pivot. Check that the acorn nut is completely threaded on to the armature of the solenoid, and that the armature spring is in place. Hook the extension spring between the pawl and the grooved pin. Loosen the screws securing the solenoid. Using a 6-inch scale, check the $14/64 \pm 1/64$ inch gap between the pawl and the mounting plate (Figure 6-1). With the solenoid armature retracted and the acorn nut against the pawl, tighten the solenoid mounting screws. Remove the shim or feeler gage and check that the pawl/plate gap is correct.

- d. Install the spindle lock assembly on the base of the spindle. At the mounting point used in common by the spindle lock assembly and the switch mounting bracket, the spindle lock assembly faces against the spindle casting. Restore the four electrical connections to the lock assembly. Proceed to step 6.
5. Replace the drive belt as follows:
 - a. Disconnect the spring to the drive belt idler arm. Lift the belt clear of the motor pulley.
 - b. Remove the two socket head screws securing the switch mounting bracket to the base of the spindle assembly. Carefully lower the assembly clear of the spindle.
 - c. Thread the belt between the pawl tip and the spindle lock disk. Allow the belt to fall free of the spindle assembly.
 - d. Place a loop of the replacement drive belt around the spindle drive pulley so that when the belt is extended toward the motor pulley, it passes on both sides of the spindle casting leg between the spindle drive pulley and the motor pulley. Place the drive belt over the motor drive pulley. Make certain that the belt is not twisted and that the smooth surface of the belt faces against the pulleys.
 - e. Note the free length of the idler arm spring. Connect the spring to the idler arm. The spring must extend $1-1/4 \pm 1/4$ inch from its free length when connected to the idler arm. Loosen the three bolts securing the drive motor assembly to the bottom of the main deck and reposition the drive motor assembly to meet the requirement.
 - f. Assemble the switch mounting bracket to the base of the spindle with two socket head screws. Use two washers between the bracket and the casting leg at the right-hand end of the bracket (use one washer between the left-hand screw and the bracket). Secure the loose end of the ground cable with the screw in the right-hand end of the bracket.
 6. Connect the unit power cord. Set the power supply MAIN POWER circuit breakers to ON. Place a disk pack on the spindle and tighten it in place. Set the MAIN POWER circuit breaker to OFF and disconnect the power cord.

7. Using a feeler gage, check that the gap between the static discharge contact arm and the Pack-On switch actuator meets the requirement of Figure 6-2. Loosen the two screws securing the microswitch bracket to the switch mounting bracket and slide the bracket vertically to attain the correct dimension. Tighten the screws. Make certain that the static discharge contact is aligned to the lockshaft according to Figure 6-2. The contacts will be damaged during operation if not properly aligned.

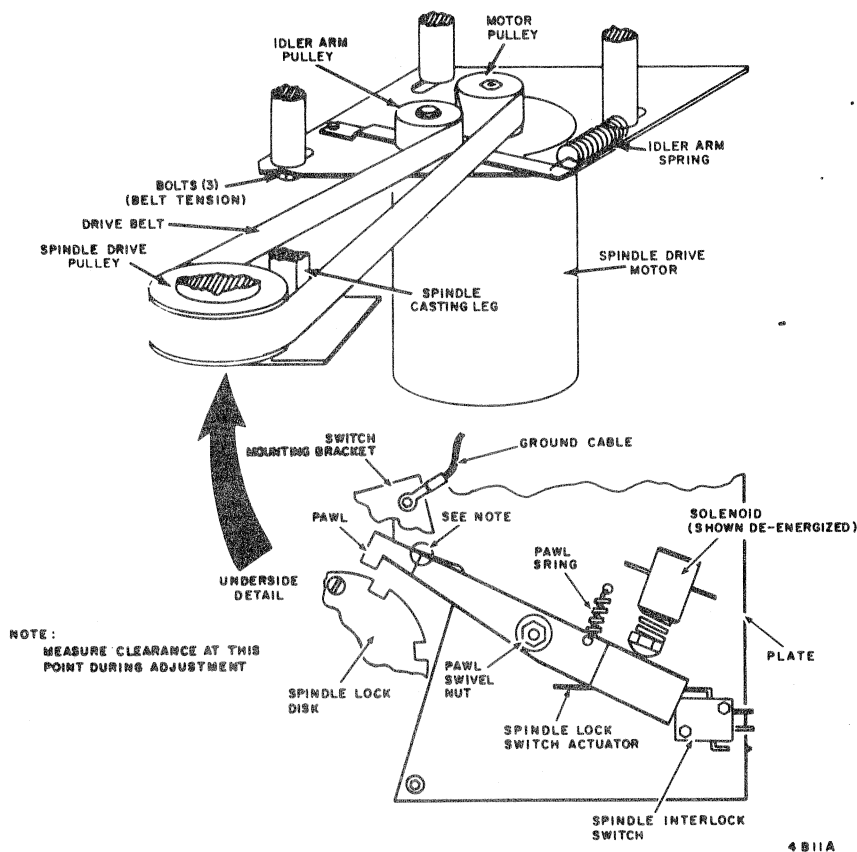
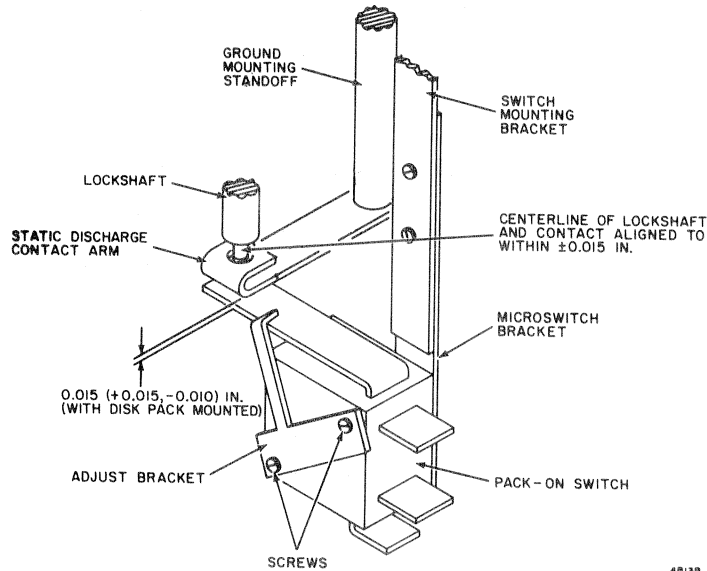

Figure 6-1. Lock and Belt Adjustment



4813B

PACK-ON SWITCH OR STATIC DISCHARGE CONTACT REPLACEMENT (Figure 6-2)

1. Press (to extinguish) the START switch. Set the power supply MAIN POWER and DC INPUT POWER circuit breakers to OFF. Disconnect both the line voltage power cords.
2. Remove the disk drive front panel and swing the logic chassis out.
3. Note or tag all electrical connections to the Pack-On switch and the static discharge terminals. Disconnect each connection.
4. Remove the two screws and four washers holding the microswitch bracket to the switch mounting bracket.
5. Proceed to step 6 for Pack-On Switch Replacement or step 7 for Static Discharge Contact Replacement.
6. Replace the Pack-On switch as follows:
 - a. Remove the two screws, three washers, and the nut securing the adjust bracket, the ground cable, and the faulty switch to the microswitch bracket.

- b. Apply 2 drops of Loctite, Grade C, to the screw threads. Loosely assemble the adjust bracket, the ground cable, and the replacement switch to the microswitch bracket.
 - c. Position the adjust bracket to keep the switch actuation arm downward-travel (before switching) to an absolute minimum. Make certain, however, that this position allows switching to occur again when the switch actuation arm moves upward. Tighten the screws.
 - d. Proceed to step 8.
7. Replace the static discharge contact as follows:
 - a. Remove the screw securing the static discharge contact arm to the bottom of the ground mounting standoff.
 - b. Install the replacement static discharge contact arm. The arm must be mounted between the terminal and the standoff. Make certain that the contact and the lockshaft center lines are aligned and that the contact arm and the lockshaft are not in contact. Tighten the screw to secure the contact arm.
8. Loosely assemble the microswitch bracket to the switch mounting bracket with two screws and four washers.
9. Restore the electrical connections at the Pack-On switch and the static discharge contact terminals.
10. Connect the unit power cords. Set the power supply MAIN POWER and DC INPUT POWER circuit breakers to ON. Place a disk pack on the spindle and tighten it in place. Set the MAIN POWER and DC INPUT POWER circuit breakers to OFF and disconnect the power cords.
11. Using a feeler gage, check that the gap between the static discharge contact arm and the Pack-On switch actuator meets the requirement of Figure 6-2. Slide the microswitch bracket vertically to attain the correct dimension. Tighten the screws.

BRUSH MOTOR REPLACEMENT

1. Press (to extinguish) the START switch.
2. Disconnect the line voltage power cord.
3. Open and latch the disk storage drive top rear cover.
4. Remove the four screws and washers holding the plastic shroud. Set the shroud aside.
5. Disconnect the J11-P11 connection.
6. Remove the two screws and washers securing the brush assembly to the main deck. Remove the assembly from the disk storage drive.
7. Note the motor leadwire connections and disconnect them.
8. Loosen the two setscrews in the brush motor link. Disconnect the link from the motor shaft.
9. Remove the two screws securing the motor to the brush assembly base. Remove the motor.
10. Using two screws and two drops Loctite, Grade C, mount the replacement motor on the brush assembly base.
11. Restore the leadwire connections according to step 7.
12. Position the brush holder against the rubber stop (Figure 6-3).
13. Connect the brush motor link to the motor shaft. Align the linkage as it appears in Figure 6-4. Tighten the two setscrews.
14. Mount the brush assembly on the disk storage drive with two screws and washers. Do not tighten.
15. Connect J11 to P11.
16. Connect the disk drive power cord. Set the MAIN POWER circuit breaker to ON.
17. Install a disk pack.
18. Align the curved edge of the brush holder parallel to the disk pack. Make certain the brush holder is against the rubber stop.
19. Manually swing the sweeper arms to the extreme position to ensure that the ends of the brushes do not hit the hub of the disk pack.

20. Tighten the two brush assembly mounting screws.

NOTE

If the disk drive is not connected to the controller, a jumper wire must be connected between pins R and U of connector J102.

21. Pull upward on the rear cover interlock switch.
22. Press (to light) the START switch. The brushes should make one 52 second pass into the disk pack and return to the retract position.
23. Press (to extinguish) the START switch.
24. Remove the disk pack.
25. Install the shroud with four screws and washers. Make certain the carriage, sector/presector block, and the brush assembly fit properly through the openings in the shroud. Pull the shroud toward the front of the unit to ensure that it protects the heads when the carriage is in the retracted position.
26. Remove jumper wire from pins R and U of J102 if used.

BRUSH RESET SWITCH REPLACEMENT

1. Press (to extinguish) the START switch.
2. Disconnect the line voltage power cord.
3. Open and latch the disk drive top rear cover.
4. Remove the four screws and washers securing the plastic shroud. Set the shroud aside.
5. Note the switch leadwire connections and disconnect them.
6. Remove the two screws and washers securing the reset switch to the brush assembly.
7. Install the replacement switch with two screws and washers.
8. Restore the leadwire connections to the reset switch according to step 5.

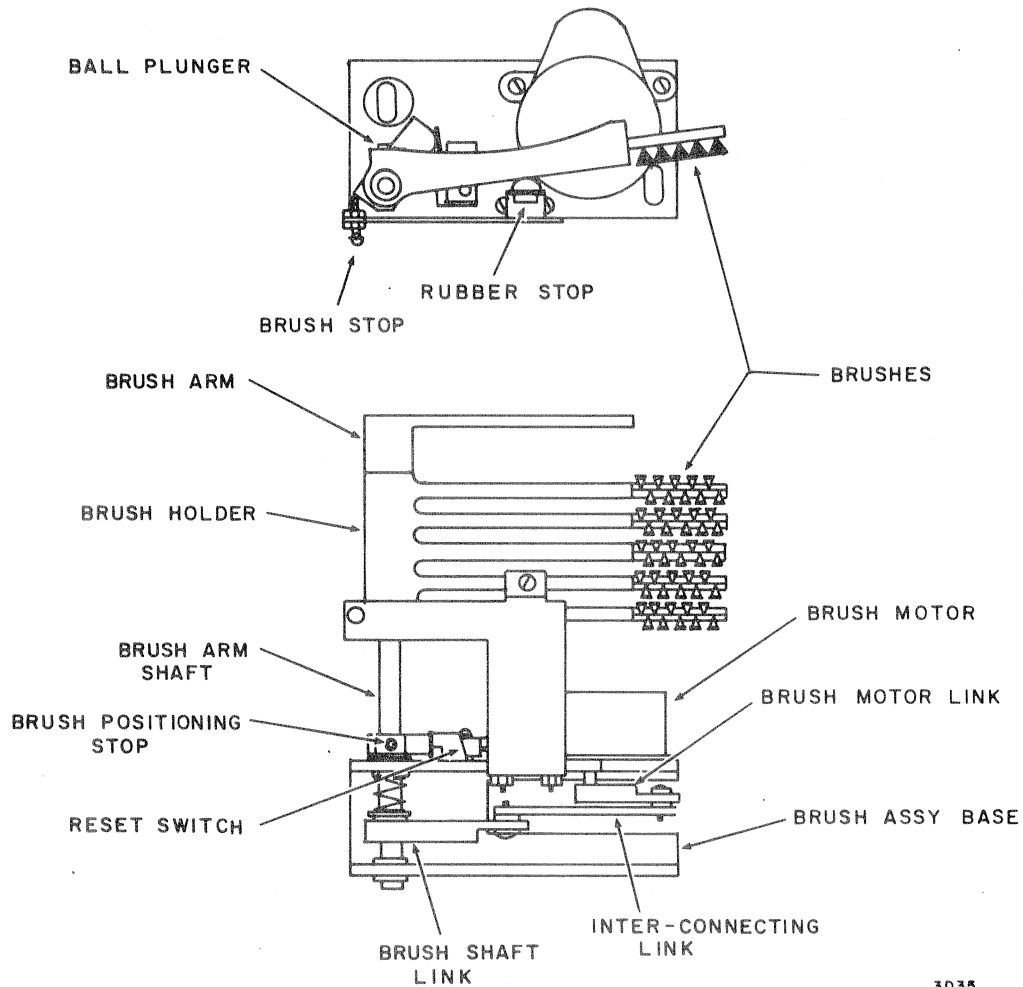

3D35

Figure 6-3. Brush Assembly

9. Move the brush holder against the rubber stop so that the linkage appears as it is in Figure 6-4.
10. Loosen the two setscrews in the brush positioning stop (Figure 6-3).
11. Adjust the stop so that the switch lever is moved approximately 1/32 inch beyond where the switch makes an audible click.
12. Tighten the two setscrews in the brush positioning stop.
13. Install the shroud with four screws and washers. Make certain the carriage, sector/presector block, and the brush assembly fit properly through the openings in the shroud. Pull the shroud toward the front of the unit to ensure that it protects the heads when the carriage is in the retracted position.

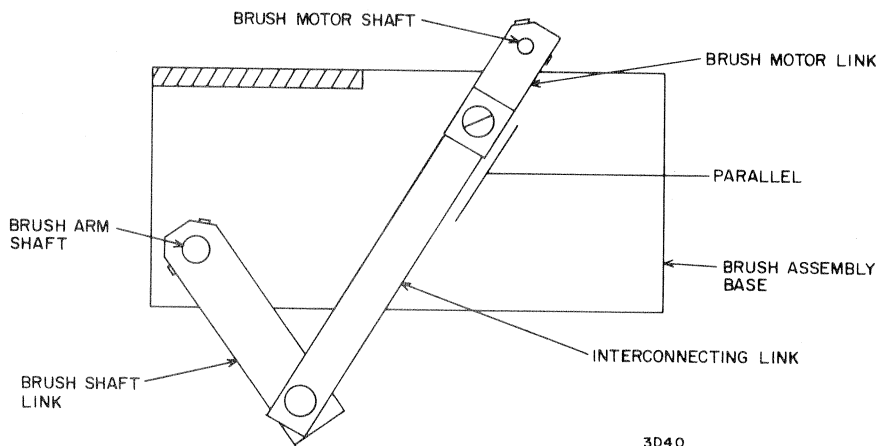

Figure 6-4. Brush Linkage Adjustment

FIBER OPTIC SOURCE LAMP REPLACEMENT

1. Press (to extinguish) the START switch.
2. Disconnect the line voltage power cord.
3. Open and latch the disk drive top rear cover.
4. Remove the four lamp housing screws.
5. Disconnect the P36-J36 connection.

CAUTION

The fiber optics may be damaged if they are pinched or bent at a radius of less than one inch.

6. Invert the lamp housing assembly and remove the three nylon mounting screws. Be careful not to lose the three insulating washers.
7. Remove the lamp assembly.

8. Remove the lamp connector. Loosen the two mounting screws and remove the lamp.
9. Install the new lamp. Tighten the two mounting screws. The strap and plate should be flush with the top of the metallic lamp base.
10. Install the lamp connector.
11. Using the three nylon screws and washers, remount the lamp assembly in the lamp housing. Do not overtighten the screws. Make sure the lamp is insulated from the housing assembly.
12. Remount the lamp housing assembly to the main deck with the four housing screws.
13. Connect P36 to J36.
14. Perform the Fiber Optic Adjustment procedure.

FIBER OPTIC REPLACEMENT

1. Press (to extinguish) the START switch.
2. Disconnect the line voltage power cord.
3. Open and latch the disk drive top rear cover.

CAUTION

The fiber optics may be damaged if they are pinched or bent at a radius of less than one inch.

4. Disconnect the defective fiber optic from the clip end.
5. Remove the fiber optic from the cable clamps up to the lamp housing assembly.
6. Note the orientation of the fiber optics and ball joint retaining plate at the housing assembly (Figure 6-5). Mark the retaining plate.
7. Remove the five screws from the ball joint retaining plate.
8. Gently lift the fiber optics vertically and remove the center screw from the plate. Do not lose the small spacer under the center screw.

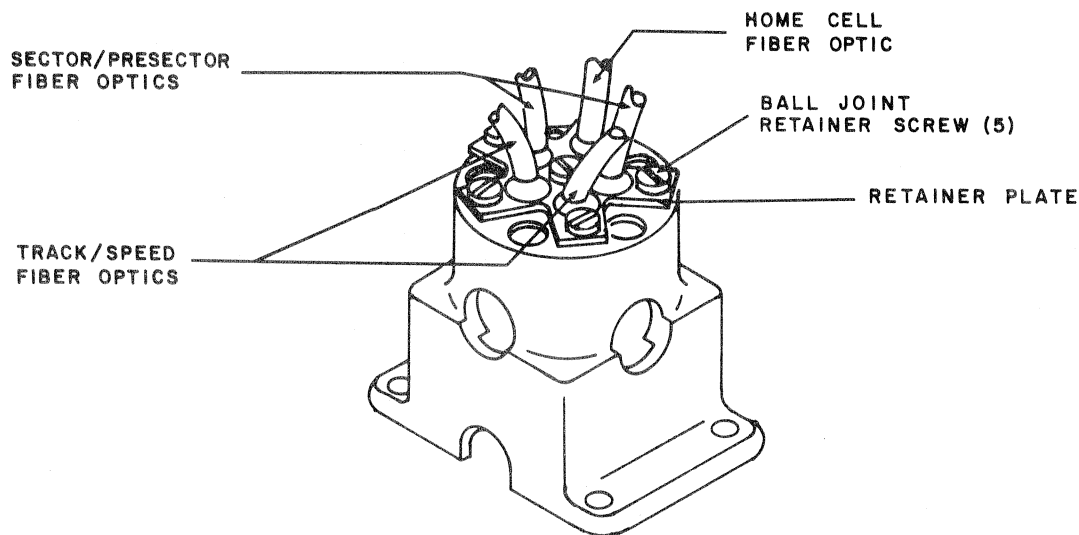

3034

Figure 6-5. Fiber Optic Source Lamp

9. Slide the damaged fiber optic through the ball joint retaining plate.
10. Install the new fiber optic.
11. Place the small spacer over the center tapped hole on the lamp housing assembly.
12. Insert the center screw through the ball joint retaining plate.
13. Note the marked orientation of the plate and fiber optics from step 6. Lower the fiber optics and retaining plate on the lamp housing assembly by gently pushing down on the center screw with a screwdriver. Lift up on the fiber optics to seat the ball joint ends in the plate. Tighten the center screw.
14. Insert the five retainer plate screws. Do not tighten.
15. Reroute the new fiber optic through the cable clamps.
16. Perform the Fiber Optic Adjustment procedure.

HOME CELL PHOTOTRANSISTOR REPLACEMENT

1. Press (to extinguish) the START switch.
2. Disconnect the line voltage power cord.
3. Open and latch the disk drive top rear cover.
4. Note or tag the two leadwires connected to the phototransistor plate and disconnect them.
5. Disconnect the fiber optic from the end clip.
6. Remove the two screws securing the photocell block to the mounting bracket.
7. Remove the two screws holding the phototransistor plate to the photocell block.
8. Install the replacement phototransistor plate using two screws and two drops Loctite, Grade C.
9. Secure the photocell block to the mounting bracket with two screws and two drops Loctite, Grade C. Keep the dimension between the phototransistor plate and the mask to a minimum.
10. Restore the leadwire connections to the phototransistor plate according to step 4.
11. Insert the fiber optic into the photocell clip. Adjust the fiber optic at the clip end until the clip contacts the shoulder of the end ferrule.
12. Perform the Home Cell Mechanical Adjustment procedure.

SECTOR/PRESECTOR PHOTOTRANSISTOR REPLACEMENT

1. Press (to extinguish) the START switch.
2. Disconnect the line voltage power cord.
3. Open and latch the disk drive top rear cover.
4. Note or tag the three leadwires connected to the phototransistor plate and disconnect them.
5. Remove the two screws securing the phototransistor plate to the photocell block.

6. Apply 2 drops of Loctite, Grade C, to the screw threads and install the replacement phototransistor plate.
7. Restore the leadwire connections to the phototransistor plate according to step 4.
8. Perform the Sector/Presector Block Tangential and Radial Adjustment procedure.

TRACK/SPEED PHOTOTRANSISTOR REPLACEMENT

1. Press (to extinguish) the START switch.
2. Disconnect the line voltage power cord.
3. Open and latch the disk drive top rear cover.
4. Note or tag the two leadwires connected to the applicable phototransistor plate (Figure 6-6) and disconnect them.
5. Disconnect the fiber optic from the photocell clip.
6. Loosen the two photocell clamp screws. Remove the photocell block.
7. Remove the two screws securing the phototransistor plate to the photocell block.
8. Apply 2 drops of Loctite, Grade C, to the threads of the two screws and install the replacement phototransistor plate.
9. Insert the photocell block in the photocell clamp. Tighten the clamp screws.
10. Restore the leadwire connections to the phototransistor plate according to step 4.
11. Insert the fiber optic into the mounting clip until it is within $2/16 \pm 1/16$ inch of the timing disk.
12. Perform the Track/Speed Photocell Mechanical Adjustment procedure.
13. Perform the Track Photocell Rotational Adjustment procedure.
14. Perform the Actuator Dynamic Tests and Adjustments procedure.

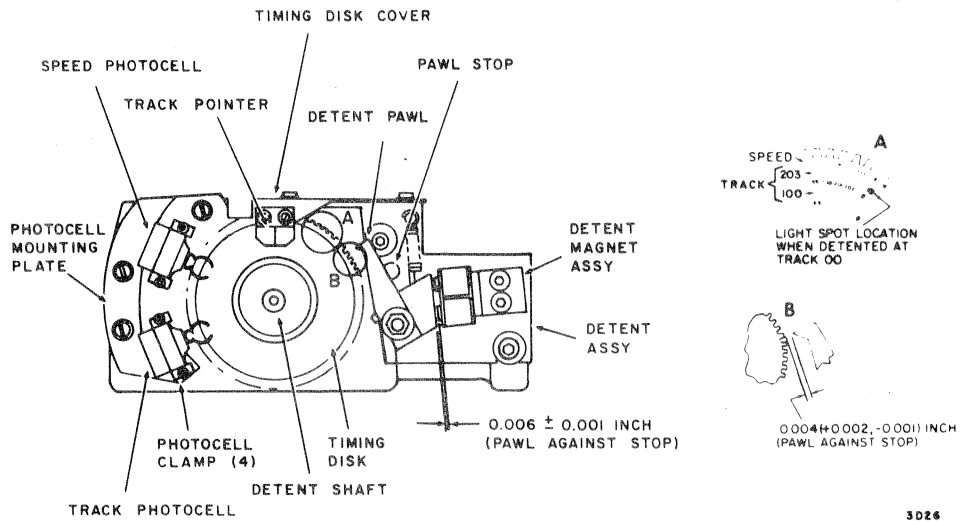

Figure 6-6. Detent Subassembly

CARRIAGE ASSEMBLY OR DETENT SHAFT REPLACEMENT

1. Open and latch the disk drive top rear cover.
2. Set the power supply MAIN POWER circuit breaker to OFF.
3. Remove the four screws and washers holding the plastic shroud. Remove the shroud and set it aside.
4. Disconnect the J230-P230 connection at the top rear of the carriage.
5. Disconnect the read/write cable from the head diode board. Remove the screw securing the cable clamp to the side of the carriage mount.
6. Remove the track/speed fiber optics from the photocell mounting clips.
7. Remove the screw securing the home cell fiber optic clamp to the head diode board. Remove the fiber optic from the photocell mounting clip.
8. Remove the four bolts securing the actuator assembly to the main deck. Lift the actuator assembly from the disk storage drive.

NOTE

Further disassembly and reassembly will be greatly aided by referring to the exploded view for the carriage assembly in the Illustrated Parts List. See Section 1 of this manual for the Publication Number.

9. Note the connection scheme, and disconnect the 10 read/write head connector plugs from the head diode board.
10. Remove the two screws securing the carriage stop bracket to the carriage assembly.
11. Remove the screw securing the ground strap to the carriage.
12. Remove the three screws securing the shock mount to the carriage mount.
13. Disengage the detent pawl and move the carriage forward so that the torsion arm shaft clears the shock mount.
14. Twist the shock mount counterclockwise to disengage it from the cam and remove it from the carriage mount.
15. Remove the two screws securing the cam latch collar to the head loading cam.
16. Locate the part of the carriage mount that surrounds the forward end of the head loading cam. Remove the retaining ring (0.831-inch OD) from the forward face.
17. For carriage assembly replacement proceed to step 18. For detent shaft replacement proceed to step 19.
18. Replace the carriage assembly as follows:

CAUTION

Do not touch the face of the heads. Skin acids can etch and damage faces. Avoid any contact between head/arm assembly being removed and any adjacent head/arm assembly.

- a. Note the orientation of the head arms and mark the arms. Refer to Figure 6-7 for head identification.
- b. Loosen the wrenching nuts in the head/arm clamp.

- c. Push the head/arm assembly toward the spindle assembly. Grasp the support arm and carefully pull it clear of the head/arm guide plate. Guide the head connector plug until it is clear of the carriage.
 - d. Referring to Figure 6-7 and step a, carefully thread the connector plug of the head, arm through the head/arm guide plate and clamp of the new carriage assembly. Align the leading end of the head/arm with the slot in the guide plate. Slide the head/arm through the slot and back to the head/arm locating block.
 - e. Repeat steps c and d for the nine remaining head/arm assemblies. Tighten the 12 wrenching nuts in the head/arm clamp.
 - f. Note or tag the five leadwire connections to the head latch assembly and disconnect them. Note the orientation of the diode on the head latch solenoid and transfer it to the new actuator assembly.
 - g. Remove the screw securing the head latch cable clamp to the home photocell mounting bracket.
 - h. Disengage the detent pawl and move the carriage forward, separating the carriage assembly from the carriage mount.
 - i. Proceed to step 20 for assembly of the new carriage.
19. Replace the detent shaft as follows:
- a. Loosen the head latch cable clamp on the home photocell mounting bracket.
 - b. Disengage the detent pawl and slide the carriage forward, separating the carriage assembly from the carriage mount.
 - c. Remove the two screws and washers securing the timing disk cover to the carriage mount.

CAUTION

The timing disk markings are a photo-emulsion. Use extreme care in removing the photocells to prevent scraping or scratching the disk.

- d. Separate the photocell mounting plate from the carriage mount by removing the three screws and washers. Carefully slide the photocells away from the center of the timing disk.

- e. Rotate the detent shaft until the setscrew in the detent gear hub is visible through the opening above the speed photocell. Remove the setscrew with a long-shaft Allen wrench.
- f. Turn the detent shaft until the detent gear hub is positioned 180 degrees from step e. Using a lock wedge removal tool (84371800), carefully push the locking wedge out of the detent gear hub. Remove the timing disk and detent gear from the detent shaft.
- g. Remove the lock washer and screw securing the torque arm to the carriage mount.
- h. Rotate the detent shaft until the setscrew securing the motor to the shaft is visible through the opening in the actuator casting. Remove the setscrew.
- i. Rotate the detent shaft until it is positioned 180 degrees from step h. Using a lock wedge removal tool (84371800), carefully push the locking wedge out of the detent shaft. Remove the motor from the detent shaft.
- j. Remove the three screws and washers securing the bearing retainer plate to the carriage mount.
- k. Slide the detent shaft assembly out of the carriage mount. Do not lose the spring washer and flatwasher at the end of the shaft.
- l. Install the spring washer and flatwasher in the bottom of the bore. Apply a light coat of oil (Texaco All-Purpose EP Lubricant, Control Data 95020400) on the detent shaft bearings and slide the new detent shaft assembly into the carriage mount.
- m. Remount the bearing retainer plate on the carriage mount with three screws and washers. Apply 2 drops of Loctite Grade C, to the screw threads. Rotate the tightening of the screws so that the retainer plate lip will fit uniformly around the detent shaft bearing.
- n. Mate the motor shaft and the detent shaft. Do not make contact between the detent shaft and the motor. Maintain a gap of 0.06 ± 0.02 inch between the motor and the end of the detent shaft.
- o. Insert the locking wedge into the detent shaft (via the threaded end of the hole). Install the setscrew.

- p. Attach the torque arm to the carriage mount with a screw and lock-washer.

CAUTION

The timing disk markings are a photo-emulsion. Use extreme care when installing the timing disk and the photocell mounting plate. Use plastic feeler gages when setting the gap.

- q. Install the timing disk and detent gear on the detent shaft.
 - r. Position the photocell mounting plate so that the speed and track photocells are approximately over their respective segments of the timing disk and secure the plate with three screws and washers.
 - s. Using a plastic feeler gage, establish a gap of 0.004 ± 0.002 inch between the phototransistor plate and the emulsion side of the timing disk. Maintain this gap while installing the locking wedge in the detent shaft. Install the setscrew.
 - t. Install the timing disk cover and cable clamp with two screws and washers. Make certain the track indicator index does not contact the timing disk.
20. Lubricate the detent and pinion gears and the carriage assembly according to the procedures outlined in Section 5 of this manual.
21. Disengage the detent pawl and carefully slide the carriage assembly into the carriage mount. As the head loading cam exits the front hole in the carriage mount, place the spring and then the cam latch collar over the head loading cam. Make certain the cam latch collar stays forward of the cam latch arm. Slide the carriage to the rear of the carriage mount. Using Loctite, Grade C, on the screw threads, secure the cam latch collar to the head loading cam with two screws.
22. Seat the cam lug washer, the spring, and the spring retainer washer in the carriage mount. Using the compression tool (84356100), force the spring retainer washer into the carriage mount. Insert the retaining ring (0.831-inch OD) into the groove of the carriage mount to hold the washer and spring in place.

23. Apply a light coat of oil (Texaco All-Purpose EP Lubricant, Control Data 95020400) to the rear grooves of the shock mount. Using three screws and two drops Loctite, Grade C, install the carriage shock mount.
24. Connect the ground cable to the carriage assembly with a screw and washer.
25. Install the carriage stop bracket with two screws and two drops of Loctite, Grade C.
26. If the carriage assembly was replaced, connect the leadwires to the head latch assembly according to step 18 (f). If the detent shaft was replaced, tighten the head latch cable clamp on the home photocell mounting bracket.
27. Thread the head/arm cables through the cable retainer connected to the head latch assembly. Connect the cable plugs to the head diode board according to step 9.
28. Perform the Carriage Limit Stop Adjustment procedure.
29. Using the four bolts, remount the actuator assembly on the main deck of the disk storage drive.
30. Insert the home cell fiber optic into the photocell clip so that the shoulder of the fiber optic end ferrule contacts the clip. Secure the fiber optic clamp to the head diode board with a screw and washer.
31. Insert the track/speed fiber optics into the photocell mounting clips until they are within $2/16 \pm 1/16$ inch of the timing disk.
32. Connect the read/write cable to the head diode board. Using a screw and washer, secure the cable clamp to the side of the carriage mount.
33. Restore the P230-J230 connection.
34. Perform steps 8 through 13 of the Head/Arm Replacement procedure.
35. Perform the Detent Adjustment procedure.
36. Perform the Track/Speed Photocell Mechanical Adjustment procedure.
37. Perform the Track Photocell Rotational Adjustment procedure.
38. Perform the Actuator Dynamic Tests and Adjustments procedure.

39. Install the plastic shroud with four screws and washers. Make certain the carriage, sector/presector block, and the brush assembly fit properly through the openings in the shroud. Pull the shroud toward the front of the unit to ensure that it protects the heads when the carriage is in the retracted position.

TIMING DISK/DETENT GEAR ASSEMBLY REPLACEMENT

1. Press (to extinguish) the START switch.
2. Disconnect the line voltage power cord.
3. Open and latch the disk drive top rear cover.
4. Separate the timing disk cover from the carriage mount by removing the two screws and washers (Figure 6-6).

CAUTION

The timing disk markings are a photo-emulsion. Use extreme care in removing the photocells to prevent scraping or scratching the disk.

5. Remove the three screws securing the photocell mounting plate and carefully slide the photocells away from the center of the timing disk until they are clear of the detent gear teeth (Figure 6-6).
6. Manually disengage the detent pawl and move the carriage forward until the screw in the detent gear hub is visible through the opening above the speed photocell. Remove the screw with a long-shaft Allen wrench.
7. Disengage the detent pawl and move the carriage until the detent gear hub is positioned 180 degrees from step 6. Using a lock wedge removal tool (84371800), carefully push the locking wedge out of the detent gear hub. Remove the timing disk and detent gear from the detent shaft.

CAUTION

The timing disk markings are a photo-emulsion. Use extreme care and plastic feeler gages when setting the gap.

8. Install the replacement timing disk and detent gear on the detent shaft. Insert the locking wedge into the detent hub (via the threaded end of the hole).
9. Using a plastic feeler gage, establish a gap of 0.004 ± 0.002 inch between the phototransistor plate and the emulsion side of the timing disk. Maintain this gap while installing the locking wedge in the detent shaft. Install the setscrew in the detent gear hub.
10. Install the timing disk cover and cable clamp with two screws and washers. Make certain the track indicator index does not contact the timing disk.
11. Perform the Detent Adjustment procedure.
12. Perform the Track/Speed Photocell Mechanical Adjustment procedure.
13. Perform the Track Photocell Rotational Adjustment procedure.
14. Perform the Actuator Dynamic Tests and Adjustments procedure.

ACCESS MOTOR REPLACEMENT

NOTE

Field repair of the access motor is not recommended. Return faulty motor to the factory for repair.

1. Press (to extinguish) the START switch.
2. Disconnect the line voltage power cord.
3. Open and latch the disk drive top rear cover.
4. Remove the four screws and washers holding the plastic shroud. Set the shroud aside.
5. Remove the lockwasher and screw securing the torque arm to the carriage mount.

6. Manually disengage the detent pawl and move the carriage forward until the screw in the detent shaft is visible through the opening in the actuator casting. Remove the screw with a long-shaft Allen wrench.
7. Manually disengage the detent pawl and position the carriage until the detent shaft is positioned 180 degrees from step 6. Using a lock wedge removal tool (84371800), carefully push the locking wedge out of the detent shaft.
8. Disconnect the J230 -P230 connection at the top rear of the carriage mount.
9. Note the motor leadwire pin positions in J230. Using an extraction tool (12210915), remove the motor leadwires from J230.

CAUTION

Pulling on the detent shaft may result in a scored or broken timing disk. If the motor cannot be easily removed, it may be necessary to remove the gear and timing disk to prevent damage before proceeding with motor removal.

10. Carefully separate the motor and torque arm assembly from the detent shaft.
11. Remove the screw and conical shakeproof lockwasher attaching the torque arm and washer to the faulty motor and remount the arm on the new motor.
12. Mate the motor shaft and the detent shaft. Do not make contact between the detent shaft and the motor. Maintain a gap of 0.06 ± 0.02 inch between the motor and the end of the detent shaft.
13. Insert the locking wedge into the detent shaft (via the threaded end of the hole). Install the setscrew.
14. Attach the torque arm to the carriage mount with a screw and lockwasher.
15. Press the contact pins of the replacement motor into J230. Connect P230 to J230.
16. Manually disengage the detent pawl. Using a push-pull gage (12210797), check that the force encountered when moving the carriage from track 00 to track 202 plus one and back does not exceed 40 ounces.

17. Perform steps 2, 3, and 10 of the Track Photocell Rotational Adjustment procedure (align track indicator dial).
18. Perform the Actuator Dynamic Tests and Adjustments procedure.
19. If the four bolts securing the carriage mount to the main deck were loosened, perform the Actuator Adjustment procedure.
20. If the four bolts securing the carriage mount to the main deck were loosened, perform the Head/Arm Adjustment procedure.
21. Install the plastic shroud with four screws and washers. Make certain the carriage, sector/presector block, and the brush assembly fit properly through the openings in the shroud. Pull the shroud toward the front of the unit to ensure that it protects the heads when the carriage is in the retracted position.

DETENT PAWL REPLACEMENT

1. Press (to extinguish) the START switch. Set the power supply MAIN POWER and DC INPUT POWER circuit breakers to OFF. Disconnect both the line voltage power cords.
2. Open and latch the disk drive top rear cover.
3. Referring to the applicable part of Figure 6-6, remove the self-locking nut, the spring, and the washers securing the detent pawl. Disconnect the pawl spring.
4. Mount the replacement pawl on the shaft. Place a washer at each end of the spring. Assemble the spring and washers to the shaft and secure with the self-locking nut. Tighten the nut until the spring length is 0.50 ± 0.03 inch.
5. Connect the pawl spring.
6. Perform the Detent Adjustment procedure.

7. Perform the Head/Arm Adjustment procedure.
8. Perform the Actuator Dynamic Tests and Adjustments procedure.

DETENT MAGNET REPLACEMENT

1. Press (to extinguish) the START switch. Disconnect the line voltage power cord.
2. Open and latch the disk drive top rear cover.
3. Referring to the applicable part of Figure 6-6, remove the two socket head screws and washers securing the detent magnet.
4. Disconnect the J230-P230 connection at the top rear of the carriage. Note the detent magnet leadwire pin positions in J230. Using an extraction tool (12210915), remove the magnet contact pins from J230.
5. Press the contact pins of the replacement magnet into J230.
6. Install the new assembly with two screws and washers and Loctite, Grade C.
7. Perform the Detent Adjustment procedure.

HEAD LATCH SOLENOID OR MICROSWITCH REPLACEMENT

1. Press (to extinguish) the START switch. Disconnect the line voltage power cord.
2. Open and latch the disk drive top rear cover.
3. Remove the nut securing the head cable retainer to the carriage. Remove the three screws holding the solenoid mounting bracket to the carriage and carefully pull the assembly clear of the carriage.
4. Proceed to step 5 for head latch solenoid replacement or step 6 for Microswitch replacement.

5. Replace the head latch solenoid as follows:
 - a. Remove the two screws and washers that hold the solenoid to the bracket.
 - b. Note or tag the two leadwire connections to the solenoid and the diode orientation. Disconnect each.
 - c. Connect the leadwires and the diode to the replacement solenoid according to step b.
 - d. Apply 2 drops of Loctite, Grade C, to the screws and using the washers, secure the solenoid to the bracket.
 - e. Proceed to step 7.
6. Replace the Microswitch as follows:
 - a. Rotate the assembly so that the Microswitch is up and level.
 - b. Carefully remove the two screws and washers that secure the Microswitch and actuating mechanism to the bracket.
 - c. Carefully lift the Microswitch off the bracket and immediately install the replacement unit. Apply two drops of Loctite, Grade C, to the threads and secure the switch to the bracket with two screws and washers.
 - d. Transfer the leadwire connections from the faulty Microswitch to the new unit.
7. Apply 2 drops of Loctite, Grade C, to the threads and install the mounting bracket on the carriage with three screws. Secure the cable clamp with the lower screw. Using a nut, secure the head cable retainer to the carriage assembly.
8. Perform the Head Latch Solenoid and Switch Adjustment procedure.

CAM LATCH SOLENOID REPLACEMENT

1. Press (to extinguish) the START switch. Disconnect the line voltage power cord.

2. Open and latch the disk drive top rear cover.
3. Remove the three screws and washers securing the cam latch solenoid bracket to the carriage.
4. Note or tag the two leadwire connections to the solenoid and the diode orientation and disconnect each.
5. Remove the two screws securing the solenoid to the bracket.
6. Apply 2 drops of Loctite, Grade C, to the screws and install the replacement solenoid on the bracket.
7. Connect the leadwires and the diode to the replacement solenoid according to step 4.
8. Apply 2 drops of Loctite, Grade C, to the screws and using the washers, secure the bracket to the carriage.
9. Perform the Cam Latch Solenoid Adjustment procedure.

HEAD/ARM REPLACEMENT

1. Press (to extinguish) the START switch. Set the power supply MAIN POWER and DC INPUT POWER circuit breakers to OFF. Disconnect both the line voltage power cords.
2. Open and latch the disk drive top rear cover.
3. Determine the faulty head. Refer to Figure 6-7 for the physical location of the head.
4. Disconnect the connector plug for the faulty head at the head diode board.
5. Loosen the wrenching nuts immediately above and below the faulty head/arm (Figure 6-7).

CAUTION

Do not touch the face of the heads. Skin acids can etch and damage the faces. Avoid any contact between the head/arm assembly being removed and any adjacent head/arm assembly.

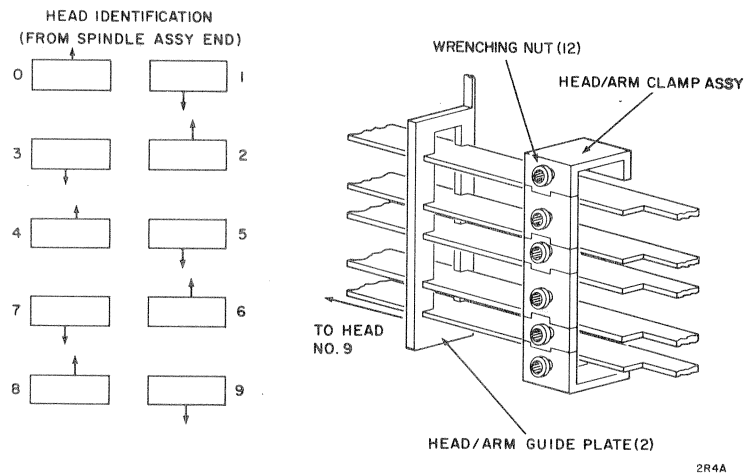

Figure 6-7. Head/Arm Assembly Adjustment

6. Push the head/arm assembly toward the spindle assembly. Grasp the support arm and carefully pull it clear of the head/arm guide plate. Guide the head connector plug until it is clear of the carriage.
7. Carefully thread the connector plug for the replacement head/arm through the head/arm guide plate and clamp. Align the leading end of the head/arm with the slot in the guide plate. Slide the assembly toward the rear of the carriage until alignment is approximately the same as the adjacent head/arm assemblies. Connect the head connector plug. Using a torque Allendriver (84255000), tighten the wrenching nuts in the head/arm clamp to 6 ± 0.5 inch-pounds.

NOTE

If the disk drive is not connected to the controller, a jumper wire must be connected between pins R and U of connector J102.

8. Connect the unit power cord. Set the MAIN POWER and DC INPUT POWER circuit breakers to ON. Install a disk pack.

9. Manually pull the detent and move the heads slowly into the pack. Make certain that no part of the carriage (cable, cable clamp, torsion arm, or head) contacts the disk. Prior to latching, the replacement head should approach the disk with the outside and rear edges leading. Return the carriage to the retracted stop.
10. Set the ACCESS MOTOR circuit breaker to OFF. Pull upward on the top rear cover interlock switch (behind carriage). Press (to light) START switch.
11. Repeat the checks of step 9.
12. Perform the Head/Arm Adjustment procedure.
13. Perform the Actuator Adjustment procedure.
14. Remove jumper wire from pins R and U of J102 if used.

TORSION ARM/SHAFT REPLACEMENT

1. Open and latch the top rear cover.
2. Set the power supply MAIN POWER circuit breaker to OFF.
3. Remove the four screws and washers holding the plastic shroud. Remove the shroud and set it aside.
4. Note the connection scheme and disconnect the 10 read/write head connector plugs from the head diode board.
5. Loosen the 12 wrenching nuts (Figure 6-7) through the head/arm clamp.

CAUTION

Do not touch the face of the heads. Skin acids can etch and damage the faces. Avoid any contact between head/arm assembly being removed and any adjacent head/arm assembly.

6. Note the orientation of the head arms and mark the arms. Refer to Figure 6-7 for head identification.
7. Push the head/arm assembly toward the spindle assembly. Grasp the support arm and carefully pull it clear of the head/arm guide plate. Guide the head connector plug until it is clear of the carriage. Repeat this step for the nine remaining heads.

8. If the center torsion arm is to be replaced, go to step 9. If one of the other four torsion arms is to be replaced, go to step 10.
9. Replace the center torsion arm assembly as follows:
 - a. Disengage the detent pawl and move the carriage to the fully retracted position. Note the carriage track location for later use.

NOTE

Further disassembly and reassembly will be greatly aided by referring to the exploded view for the carriage assembly in the Illustrated Parts List. See Section 1 of this manual for the Publication Number.

- b. Remove the two screws securing the carriage stop bracket to the carriage assembly. Remove the screw securing the ground strap to the carriage.
- c. Remove the three screws securing the shock mount to the carriage mount. Disengage the detent pawl and move the carriage forward so that the torsion arm shaft clears the shock mount. Twist the shock mount counterclockwise and remove it from the carriage mount.
- d. Remove the two screws securing the cam latch collar to the head loading cam. Locate the part of the carriage mount that surrounds the forward end of the head loading cam. Remove the retaining ring (0.831-inch OD) from the forward face.
- e. Locate the nut securing the head cable retainer. Remove the nut and the retainer. Remove the three screws securing the heads loaded latch assembly to the carriage.
- f. Disengage the detent pawl and move the carriage forward, separating the carriage assembly from the carriage mount.
- g. Remove the torsion arm assemblies (except the center torsion arm) from the carriage by releasing the retaining ring at the end of the torsion arm shaft.

- h. Note the orientation of the cam follower (pinned on end of torsion shaft) for use during reassembly. Use a punch to remove the 3/32 inch diameter roll pin that secures the cam follower to the torsion shaft.
- i. Note the orientation of the heads loaded latch arm (pinned to approximate center of torsion shaft) for use during reassembly. Use a punch to remove the 3/32-inch diameter roll pin that secures the latch arm to the torsion shaft. Slide the center torsion arm (and torsion shaft) out of the carriage.
- j. Slide the replacement center torsion arm (and torsion shaft) into the carriage. Stop sliding the torsion shaft when the end of the shaft is just visible in the opening of the carriage casting.

CAUTION

The damping cylinder is fragile glass. Use care when handling.

- k. Seat the unloading damper piston in the damping cylinder (mounted on side of carriage). Place the heads loaded latch arm (oriented according to step i) and the thrust bearing over the end of the shaft and slide the torsion shaft through the remainder of the carriage. Pin the heads loaded latch arm to the torsion shaft with the roll pin (3/32 x 1/2 inch).
- l. In the following order, slide the retaining ring (0.831-inch OD), the spring retaining washer (small OD first), the spring (smaller of the two available), and the cam lug washer (lug end first) on the end of the torsion shaft.
- m. Slide the head loading cam (notched end first) on the end of the torsion shaft until the shaft end is just visible in the opening cut in the side of the cam. Place the cam follower (lug end to the rear) in the cam opening and slide the torsion shaft through the center of the cam follower. Pin the cam follower to the end of the torsion shaft with the roll pin (3/32 x 3/8 inch).
- n. Lubricate the detent and pinion gears, carriage mount bearings, and the carriage assembly according to the procedures outlined in Section 5 of the manual.

- o. Disengage the detent pawl and carefully slide the carriage assembly into the carriage mount. As the head loading cam exits the front hole in the carriage mount, place the spring and then the cam latch collar over the head loading cam. Make certain the cam latch collar stays forward of the cam latch arm. Slide the carriage to the rear of the carriage mount. Using Loctite, Grade C, on the screw threads, secure the cam latch collar to the head loading cam with two screws.
- p. Seat the cam lug washer, the spring, and the spring retainer washer in the carriage mount. Using the compression tool (84356100), force the spring retainer washer into the carriage mount. Insert the retaining ring (0.831-inch OD) into the groove of the carriage mount to hold the washer and spring in place.
- q. Apply a light coat of oil (Texaco All-Purpose EP Lubricant, Control Data 95020400) to the rear grooves of the shock mount. Using three screws and two drops Loctite, Grade C, install the carriage shock mount.
- r. Connect the ground cable to the carriage assembly with a screw and washer. Install the carriage stop bracket with two screws and two drops of Loctite, Grade C.
- s. Disengage the detent pawl and move the carriage to the fully retracted position. Make certain that the lugs on the cam follower are pointing up and down and are located at the extreme rear of the slotted opening in the head loading cam. The center torsion spring (see point A on Figure 3-17) should be aligned to 45-degrees from vertical, running from upper right to lower left.

CAUTION

The 90-degree relationship in the next step (shown on Figure 3-17) must be closely adhered to. The disk pack and/or the head/write heads may be damaged by incorrect assembly.

- t. Place a washer over the shaft end of each torsion arm assembly and carefully install the assemblies on the carriage. The assemblies with the full set of gear teeth go immediately above and below the center torsion arm. The assemblies with the partial set of gear teeth are

the top and bottom assemblies in the stack, and the flat spot on the gear should be up on the top assembly and down on the bottom assembly. As the torsion arms are installed, mesh the gears so that a 90-degree angle is formed between adjacent faces of the torsion springs, Figure 3-17. Secure the torsion arm assemblies to the carriage with retaining rings (0.145-inch ID).

- u. Apply 2 drops of Loctite, Grade C, in the screw threads and install the heads loaded latch assembly with three screws. Install the two top screws first and then install the lower screw and the head latch cable clamp. Install the head cable retainer with a nut.
 - v. Disengage the detent pawl and move the carriage to the fully retracted position. Note the carriage track location from step a and the location now. If an adjustment must be made, remove three screws and washers securing the head diode board. Free the Delrin block by removing the screw immediately behind the Delrin block setscrew, Figure 6-13. Slide the Delrin block clear of the top of the carriage. Separate the carriage rack gear from the pinion gear by pressing downward on the rear of the carriage. Rotate the pinion gear until the carriage track location is the same as it was in step a. Allow the gears to mesh and check that the track location did not change.
 - w. Install the Delrin block with one screw. Perform the Carriage Limit Stop Adjustment procedure.
 - x. Adjust the home cell according to the Home Cell Mechanical Adjustment procedure.
 - y. Proceed to step 11.
10. Replace a torsion arm assembly (other than the center assembly) as follows:
- a. Disengage the detent pawl and move the carriage to the fully extended position.
 - b. Remove the retaining ring that secures the faulty torsion arm to the carriage. Pull the assembly clear of the carriage.

- c. Slide the washer (from old assembly) onto the shaft end of the replacement torsion arm assembly.

CAUTION

The 90-degree relationship in the next step (shown on Figure 3-17) must be closely adhered to. The disk pack and/or the head/write heads may be damaged by incorrect assembly.

- d. As the replacement assembly is installed, mesh the gears so that a 90-degree angle (see Figure 3-17) is formed between the adjacent faces of the torsion springs. Secure the new assembly to the carriage with the original retaining ring.

CAUTION

Do not touch the face of the heads. Skin acids can etch and damage the faces. Avoid any contact between head/arm assembly being installed and any adjacent head/arm assembly.

11. Referring to Figure 6-7 and step 6, carefully thread the connector plug for a head/arm assembly through the head/arm guide plate and clamp. Slide the head/arm into the slots in the guide plate and back to the head/arm locating block. Thread the head/arm cables through the cable retainer connected to the head latch assembly. Repeat this procedure for each of the nine remaining head/arm assemblies. Using a torque Allendriver (84255000), tighten the 12 wrenching nuts in the head/arm clamp to 6 ± 0.5 inch-pounds.
12. Restore the head connector plug connections according to step 4.
13. Perform steps 8 through 13 of the Head/Arm Replacement procedure.
14. Install the shroud with four screws and washers. Make certain the carriage, sector/presector block, and the brush assembly fit properly through the openings in the shroud. Pull the shroud toward the front of the unit to ensure that it protects the heads when the carriage is in the retracted position.

ADJUSTMENT

NOTE

Machine adjustments should be made only if the unit is not operating properly. Adjustments may drift outside of the tolerances provided. Such drift should not in itself be cause for adjustment.

SPINDLE LOCK ADJUSTMENT

1. Set the power supply MAIN POWER and DC INPUT POWER circuit breakers to OFF. Disconnect both the line voltage power cords.
2. Remove the front panel and swing out the logic chassis.
3. Referring to Figure 6-1, use a 6-inch scale to check the $14/64 \pm 1/64$ inch gap between the pawl and the plate (circled on figure). If this requirement is not met, remove the spindle lock assembly from the base of the spindle and adjust it according to step 4c of the Spindle Lock or Drive Belt Replacement procedure.
4. Press the armature of the spindle lock solenoid into the body of the solenoid and hold it there. Grasp the pawl and check that it rotates freely. The ends of the pawl should not be free to move vertically. Carefully allow the solenoid armature to extend.
5. Close the logic chassis and install the front panel.

PACK-ON SWITCH ADJUSTMENT

1. Set the power supply MAIN POWER and DC INPUT POWER circuit breakers to ON. Open the disk drive front cover, mount a disk pack on the spindle assembly, and tighten it in place.
2. Set the MAIN POWER and DC INPUT POWER circuit breakers to OFF. Disconnect both the line voltage power cords.
3. Open the front panel and swing out the logic chassis.

4. Using a feeler gage, check that the gap between the static discharge contact arm and the Pack-On switch actuator meets the requirements of Figure 6-2. Loosen the two screws securing the Microswitch bracket to the switch mounting bracket and slide the lower bracket vertically until the dimension is correct. Tighten the screws. Make certain that the static discharge contact is aligned to the lockshaft according to Figure 6-2. The contacts will be damaged during operation if not properly aligned.
5. Close the logic chassis and install the front panel.

DRIVE BELT TENSION ADJUSTMENT

1. Press (to extinguish) the START switch.
2. Remove the front panel and swing out the logic chassis.
3. Disconnect the spring to the drive belt idler arm. Note the free length of the spring and reconnect it to the idler arm. The spring must extend $1-1/4 \pm 1/4$ inch from its free length when connected to the idler arm.
4. If the requirement is not met, loosen the three bolts securing the drive motor assembly to the disk drive and reposition the drive motor assembly to meet the requirement. Apply 2 drops of Loctite, Grade C, to the bolt threads and tighten.

BRUSH ARM AND LINKAGE ADJUSTMENT

1. Open and latch the top rear cover of the disk storage drive.
2. Press (to extinguish) the START switch.
3. Remove the four screws and washers holding the plastic shroud. Set the shroud aside.
4. Loosen the two screws locking the brush shaft link to the brush arm shaft.

5. For brush arm adjustment proceeds to step 6. To adjust the linkage proceed to step 9.
6. Note the ball plunger in the brush holder (Figure 6-3). (Has the appearance of a setscrew.) This ball detents into a slot on the brush arm shaft. Rotate the brush holder so that the ball is not over the slot of the shaft.
7. Bottom the ball plunger on the diameter of the shaft and back off approximately 1/8 turn.
8. Rotate the brush holder and the brush arm so that the plunger is detented in the shaft slot.
9. Position the brush arm against the rubber stop.
10. Align the linkage as it appears in Figure 6-4. Tighten the two setscrews in the brush shaft link.
11. Loosen the two setscrews in the brush positioning stop (Figure 6-3).
12. Adjust the stop so that the switch lever is actuated approximately 1/32 inch beyond where the switch makes an audible click. Make certain the brush holder is against the rubber stop.
13. Tighten the two setscrews in the brush positioning stop.
14. Install the plastic shroud with four screws and washers. Make certain the carriage, sector/presector block, and the brush assembly fit properly through the openings in the shroud. Pull the shroud toward the front of the unit to ensure that it protects the heads when the carriage is in the retracted position.

FIBER OPTIC ADJUSTMENT

1. Open and latch the disk storage drive top rear cover.

NOTE

If the disk drive is not connected to the controller, a jumper wire must be connected between pins R and U of connector J102.

2. Set the DC INPUT, MAIN POWER, and ± 20 vdc circuit breakers to ON.
3. Using a multimeter, measure $+5.7 \pm 0.2$ vdc at the power supply panel LAMP and DC GRD jacks. Refer to the Power Level Adjustment procedure if the correct voltage is not read.
4. Remove the front panel and connect the ground of an oscilloscope to the maintenance panel GROUND jack. Press (to light) the START switch.
5. Proceed to step 6 for the track, speed, sector, and presector fiber optic adjustment or step 7 for the home cell fiber optic adjustment.
6. Adjust the track, speed, sector, and presector fiber optics as follows:
 - a. Connect the oscilloscope probe to the yellow leadwire terminal of the speed phototransistor plate.

CAUTION

The fiber optics may be damaged if they are pinched or bent at a bend radius of less than one inch.

- b. Mount the appropriate fiber optic in the speed cell mounting clip.
- c. Disconnect the spring from the detent pawl and move the carriage so that the speed cell output is Class A (between $+1.0$ and $+5.5$ vdc). The speed cell must not be saturated at this time.
- d. Loosen the appropriate ball joint retaining screw on the source lamp housing assembly (Figure 6-5) until the ball joint can be moved with some resistance. If the plate is deformed so that the ball is not free, lift the plate with a screwdriver while making adjustment.
- e. Move the fiber optic ball joint until the photocell output is maximum.
- f. If the phototransistor saturates, reposition the carriage so that the phototransistor output is again Class A. Readjust the fiber optic ball joint until the phototransistor output is maximum.
- g. Tighten the ball joint retaining screw.

- h. Connect the fiber optic to its original position. Insert the sector/ presector fiber optics until the clip contacts the shoulder of the end ferrule. Insert the track/speed fiber optics into the mounting clip until they are within $2/16 \pm 1/16$ inch of the timing disk.
 - i. Proceed to step 8.
7. Adjust the home cell fiber optic as follows:
- a. Adjust the fiber optic at the clip end until the clip contacts the shoulder of the end ferrule.
 - b. Connect the oscilloscope probe to the left leadwire terminal of the home cell phototransistor plate.
 - c. Disconnect the spring from the detent pawl and move the carriage so that the home cell output is Class A (between +1.0 and +5.5 vdc). The home cell must not be saturated at this time.
 - d. Loosen the home cell fiber optic ball joint retaining screw on the source lamp housing assembly (Figure 6-5) until the ball joint can be moved with some resistance. If the plate is deformed so that the ball joint is not free, lift the plate with a screwdriver while making adjustment.
 - e. Move the fiber optic ball joint until the photocell output is maximum.
 - f. If the phototransistor saturates, reposition the carriage so that the output is again Class A. Readjust the fiber optic ball joint until the phototransistor output is maximum.
 - g. Tighten the ball joint retaining screw.
8. Disconnect the oscilloscope.
9. Hook the spring over the detent pawl.
10. Remove jumper wire from pins R and U of J102 if used.

DETENT ADJUSTMENT

Refer to Figure 6-6 for the following procedure.

- 1. Press (to extinguish) the START switch.
- 2. Open and latch the top rear cover.

3. Manually disengage the detent pawl. Use a feeler gage to measure the gap between the tip of the pawl and the adjacent tops of the detent gear teeth. The gap should be 0.004 (+0.002, -0.001) inch.
4. With the pawl disengaged, use a feeler gage to measure the gap between the detent pawl armature and the pole faces of the detent magnet. The gap should be 0.006 ± 0.001 inch.
5. If the requirements of steps 3 and 4 are met, go to step 8.

NOTE

The gaps checked in steps 3 and 4 are independent of each other and can be adjusted separately.

6. To adjust the gap between the detent pawl armature and the magnet pole faces, loosen the two screws securing the detent magnet assembly until the assembly can be moved by hand. Place a 0.006-inch shim between the magnetic pole faces and the pawl armature. With the pawl against the stop, the pivot pin at the end of the slot in the pawl, and the magnet pole facing parallel to the pawl armature face, tighten the two screws securing the detent magnet assembly. Remove the shim. Check the gap (0.006 ± 0.001 inch) and readjust if required.
7. To adjust the gap between the tip of the pawl and the tops of the adjacent detent gear teeth, loosen the two screws securing the detent assembly. Place a 0.004-inch shim between the pawl tip and the tops of the adjacent detent gear teeth. Position the detent assembly until the gap is held with the pawl against the stop and the pivot pin at the end of the slot in the pawl, then tighten the two screws securing the detent assembly. Remove the shim. Check the gap for a dimension of 0.004 (+0.002, -0.001) inch and readjust if required.
8. Check the adjustment of delay Y312 according to step 5 of the Delay Tests and Adjustments procedure.
9. Attach a push-pull gage (12210797) to the neck of the detent pawl. Apply a pull force perpendicular to the pawl. The gage should indicate that a minimum force of 4 ounces is required to disengage the pawl.

HEAD/ARM ADJUSTMENT

The head/arm assemblies must be adjusted to place each of the read/write heads on the same radial position with reference to the center of the disk pack. Radial positioning is accomplished by physically moving the heads into or out of the disk pack.

NOTE

The room temperature should be maintained at $72^{\circ} \pm 6^{\circ}\text{F}$ during the entire adjustment procedure.

1. Open and latch the top rear cover of the disk drive.

NOTE

A fault will occur when the diode card at X10 is removed.

2. Remove the diode card at X10 (read/write logic chassis).
3. Remove the disk drive front panel. Connect the oscilloscope external trigger to test point C of I028 Index pulse (C27) and set the External Sync switch to negative. Ground the oscilloscope at the maintenance panel GROUND jack.

NOTE

To read any head other than head 0 or head 1, the selected head cable plug connection must be exchanged with either head 0 or head 1 at the head diode card. Connect heads 3, 4, 7, and 8 (Figure 6-7) at the head 0 head diode card connector. All other heads are exchanged with head 1.

4. Exchange the head plug connection of the desired head with either head 0 or head 1. Install a head plug adapter (46812200) between the head diode and connector and the head plug of the head to be adjusted.
5. Set the maintenance panel OFF LINE/ON LINE switch to the OFF LINE READ 0 or READ 1 position (as required by the exchange in step 4).
6. Connect 1X oscilloscope probes (to read differentially) to test points A and B of the EUC card at X09 (on read/write logic chassis).
7. Set the oscilloscope sweep frequency to 2 ms/cm.
8. Connect a jumper wire between pins R and U of connector J102.
9. Set the power supply circuit breakers to ON. Mount the CE disk pack (84357500) on the spindle and tighten in place. Pull upward on the rear cover interlock switch.

10. Press (to light) the START switch. Record the time of power application.
11. After the heads load and the carriage stops, set the power supply ACCESS MOTOR and DETENT circuit breakers to OFF.
12. Manually pull the detent pawl, move the carriage to track 73, and allow the detent pawl to engage the detent gear.
13. A 45 minute warm-up period with the top rear cover down and the heads loaded, followed by a 15 minute period with the top cover raised, must precede the following adjustment procedures.
14. Adjust the oscilloscope for a stable pattern. The pattern should be similar to Figure 6-8, part C.
15. If beat frequency envelopes are not observed, pull the detent pawl and manually move the carriage back and forth across the tracks adjacent to track 73. As the heads are moving the following linear progression should be observed on the oscilloscope:
 - a. An erased area with no signal.
 - b. An all "1's" pattern.
 - c. A pattern of beat frequency envelopes (track 73).
 - d. An all "1's" pattern.
 - e. An erased area with no signal.
16. Determine which way the head/arm must be moved to appear as shown on Figure 6-8, part C. Detent the carriage at track 73.

NOTE

Do not contact or otherwise disturb an adjacent head/arm during the following adjustments.

17. Loosen the two wrenching nuts above and below the affected head/arm, Figure 6-7. If the head/arm is located before track 73, proceed to step 18. If the head/arm is located beyond track 73, carefully slide the head/arm away from the spindle.
18. Slowly move the head/arm assembly toward the spindle assembly. Stop when the beat frequency envelopes begin to form.

19. Set the oscilloscope to display one complete revolution of the disk (2 ms/cm). The beat frequency display will now be seen as a bright pattern or envelope of nulls within the all "1's" frequency pattern, Figure 6-8, part D or E.
20. Slowly adjust the head/arm assembly toward the spindle. The envelopes of nulls will come to an absolute null at one point and then will develop into a pair of absolute nulls with lobes of greater amplitude between them. The head/arm is properly aligned over track 73 when the maximum amplitude of the two envelopes is equal to within 20 percent, Figure 6-8, part F. Using a torque Allendriver (84255000), tighten the two wrenching nuts in the head/arm clamp to 6 ± 0.5 inch-pounds.
21. Set the ACCESS MOTOR and DETENT circuit breakers to ON. Perform three First Seek operations (by pressing the START switch six times at 75-second intervals).
22. Recheck the track 73 beat frequency envelope trace on the oscilloscope. If the difference between the maximum amplitude of the two envelopes exceeds 50 percent, repeat the adjust procedure from step 16.
23. Press (to extinguish) the START switch. Remove the CE disk pack from the spindle.
24. Install the diode card at location X10 on the read/write logic chassis.
25. Remove the jumper installed in step 8.
26. Remove the head plug adapter. Restore the head plug connections to the original configuration.

ACTUATOR ADJUSTMENT

1. Open and latch the top rear cover of the disk drive.

NOTE

A fault will occur when the diode card at X10 is removed.

2. Remove the diode card at X10 (read/write logic chassis).
3. Remove the disk drive front panel. Connect the oscilloscope external trigger to test point C of I028 Index pulse (C27) and set the External Sync switch to negative. Ground the oscilloscope at the maintenance panel GROUND jack.

4. Connect 1X oscilloscope probes (to read differentially) to test points A and B of the EUC card at X09 (on read/write logic chassis).
5. Set the oscilloscope sweep frequency to 5 μ sec/cm.
6. Connect a jumper wire between pins R and U of connector J102. Set the power supply circuit breakers to ON.
7. Mount the CE disk pack (84357500) on the spindle and tighten in place. Pull upward on the rear cover interlock switch.
8. Press (to light) the START switch. After the heads load and the carriage stops, set the power supply ACCESS MOTOR and DETENT circuit breakers to OFF.
9. Manually pull the detent pawl, move the carriage to track 03, and allow the detent pawl to engage the detent gear.
10. Set the maintenance panel OFF LINE/ON LINE switch to the OFF LINE READ 0 position.
11. Record the oscilloscope period (as well as head and track) between Index pulse and the peak of the first data pulse, Figure 6-9.
12. Set the maintenance panel OFF LINE/ON LINE switch to the OFF LINE READ 1 position. Repeat step 11.

NOTE

To read any head other than head 0 or head 1, the selected head cable plug must be exchanged with either head 0 or head 1 at the head diode card. Connect heads 3, 4, 7, and 8 (Figure 6-7) at the head 0 head diode connector. All other heads are exchanged with head 1. In either case, the maintenance panel OFF LINE/ON LINE switch must be positioned to reflect the exchange.

13. Repeat the observation of step 11 for each of the eight remaining heads.
14. The total spread for the 10 recorded periods should not exceed 8 μ sec. If this requirement is not met, replace the applicable head arm assembly. The 10 recorded periods should be within 20 ± 4 μ sec. If this requirement is not met, perform steps 31 through 33 of the Sector/Presector Block Tangential and Radial Adjustment procedure.

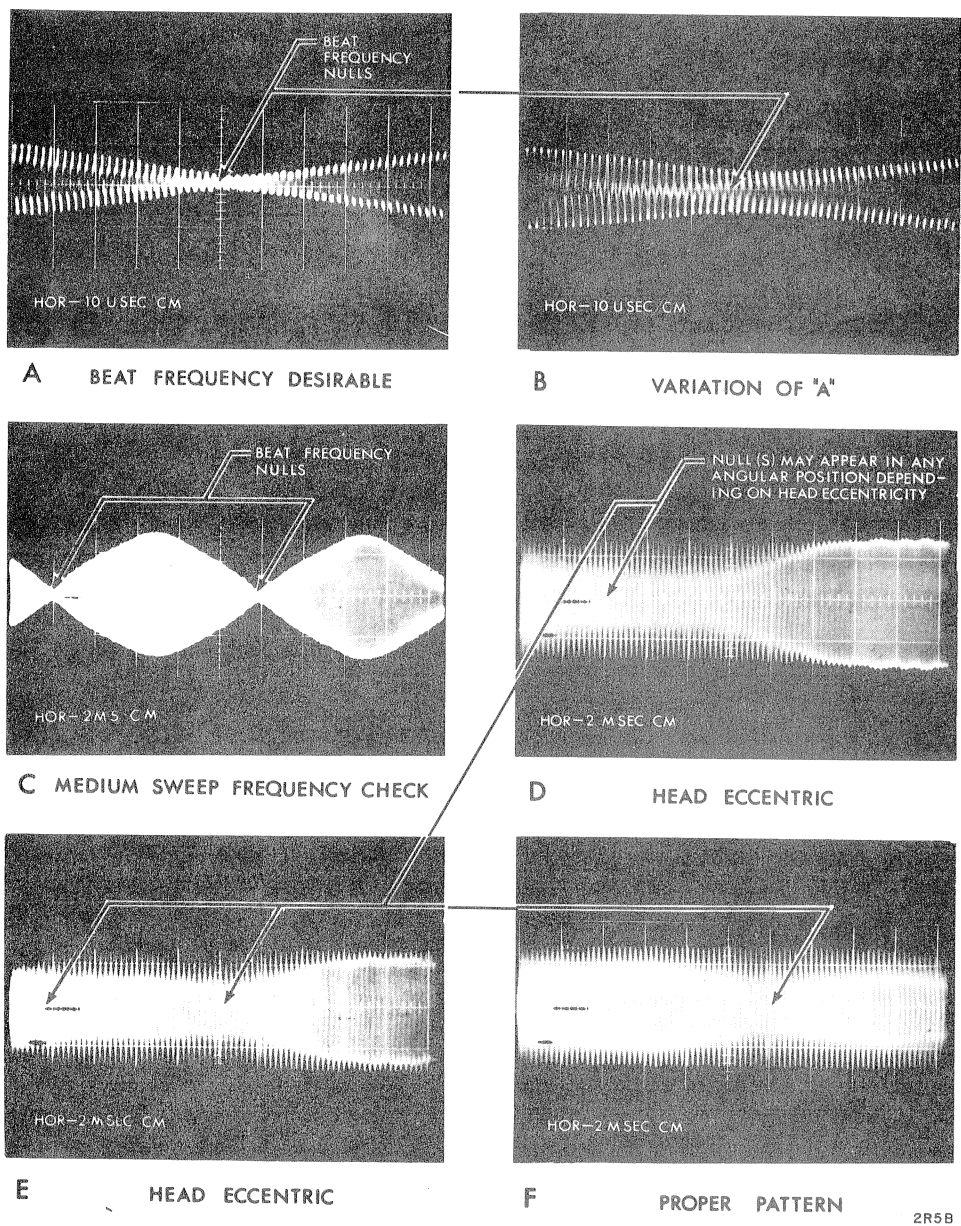

Figure 6-8. Head/Arm Adjustment

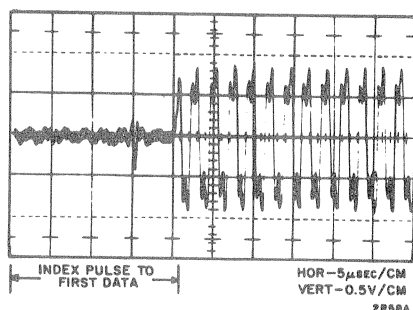

Figure 6-9. Index to Data Period

NOTE

When performing step 15, a head plug adapter (46812200) must be installed between the cable plug of the selected head and head 0 or 1 (as required) head diode card connector.

15. Install the head plug adapter (46812200) between the head 0 cable plug and the head diode card connector. Set the maintenance panel OFF LINE/ON LINE switch to the OFF LINE READ 0. Record the oscilloscope period between the Index pulse and the peak of the first data pulse (Figure 6-9). The period should be approximately 48 usec.
16. Repeat step 15 for the other nine heads.
17. Manually pull the detent pawl, move the carriage to track 201, and allow the detent pawl to engage the detent gear.
18. Repeat steps 15 and 16.
19. The difference in timing at track 03 and track 201 for any one head must not exceed 4 usec. If this requirement is met, proceed to step 22.
20. If the requirement of step 19 is not met, loosen the four bolts holding the actuator assembly to the main deck. Pivot the actuator assembly to bring the track 03 and 201 periods to within 4 μsec of each other. Tighten the bolts. Remove the head plug adapter and repeat steps 9 through 14.
21. Recheck the alignment of each head to track 73 according to the Head/Arm Adjustment procedure. Make adjustments as required.

22. Press (to extinguish) the START switch. Remove the CE disk pack from the spindle.
23. Remove the jumper wire installed in step 6.
24. Remove the head plug adapter. Restore the head plug connections to the original configuration.
25. Install the diode card at location X10 on the read/write logic chassis.

SECTOR/PRESECTOR BLOCK TANGENTIAL AND RADIAL ADJUSTMENT

NOTE

A fault will occur when the diode card at X10 is removed.

1. Open and latch the disk drive top rear cover. Remove the diode card at X10 on the read/write logic chassis.
2. Remove the disk storage drive front panel.
3. Connect a jumper wire between pins R and U of connector J102.
4. Set the power supply circuit breakers to ON.
5. Mount the CE disk pack (84357500) on the spindle and tighten in place.
6. Move the sector arm toward the disk pack until the stop post is encountered.
7. Using a plastic feeler gage, check the 0.070 ± 0.030 inch clearance (Figure 6-10).
8. If the requirement is not met, remove the shoulder screw (Figure 6-10) and add shims (p/n according to Illustrated Parts List) between the top of the mounting block and the washer.
9. Secure the sector arm with the shoulder screw.
10. Move the sector arm toward the disk pack until the stop post is encountered.
11. Using a 6-inch scale, check the $10/64 \pm 1/64$ inch clearance (Figure 6-10).
12. If the requirement is not met, loosen the stop screw locking nut.
13. Adjust the stop screw against the stop post until the clearance is correct. Tighten the locking nut.

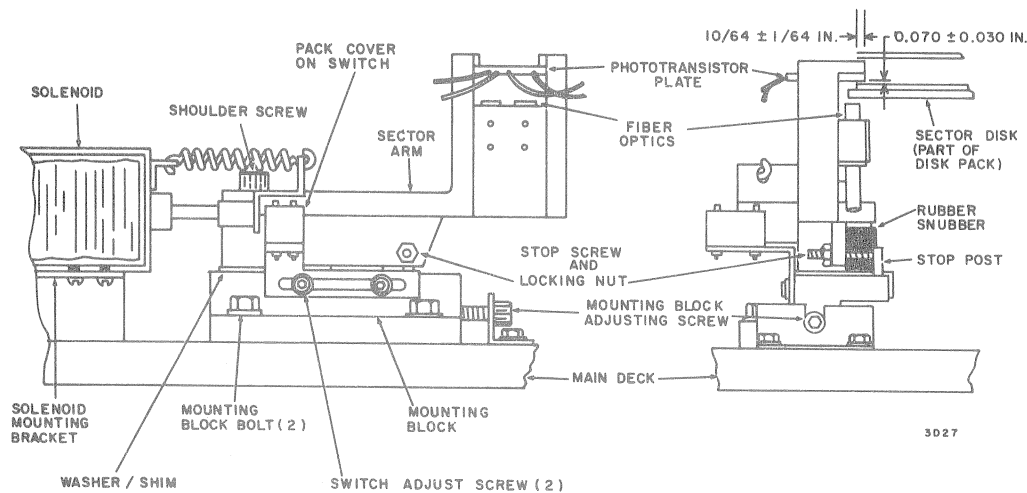

Figure 6-10. Sector/Presector Radial Adjustment

14. Move the sector/presector photocell toward the disk pack until the stop post is encountered (Figure 6-10). At this position the solenoid armature should be bottomed out. If this requirement is not met, loosen the screws in the solenoid mounting bracket and reposition the solenoid.
15. Position the sector arm against the stop post. At this position the pack cover on switch should be actuated by the sector arm (Figure 6-10). The sector arm must not touch the body of the switch. If this condition is not met, loosen the two screws securing the switch mounting bracket and reposition the switch.
16. Pull the post of the rear cover interlock switch upward.
17. Press (to light) the START switch.
18. Ground the oscilloscope at the maintenance panel GROUND jack.
19. Connect the oscilloscope probe to the yellow (presector) leadwire terminal of the sector/presector phototransistor plate.
20. The photocell analog output trace should switch between a low voltage of -0.6 ± 0.4 vdc and a high voltage of $+5.0 \pm 0.5$ vdc. The photocell must saturate at the high voltage level. The photocell is saturated if the photocell output voltage (yellow leadwire) is within 0.6 vdc of the supply voltage (black leadwire). If the photocell does not saturate, correct the

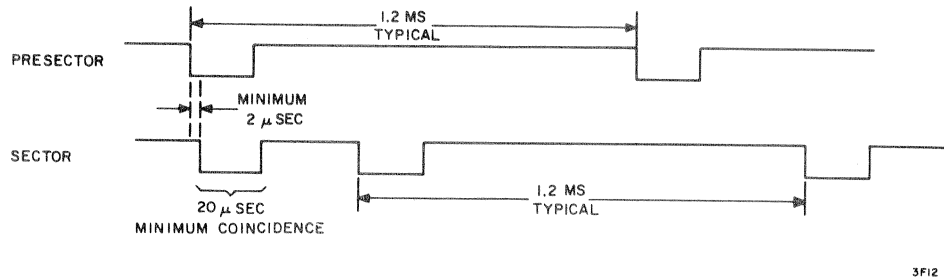

Figure 6-11. Sector/Presector Pulse Timing

situation according to one of the following:

- * Perform the Fiber Optic Adjustment procedure.
 - * Recheck steps 10 through 13 to make sure that the sector block has not moved too far into the pack.
 - * Refer to the Power Level Adjustment procedure. Adjust R03 until the cell saturates (do not exceed +6.0 vdc).
 - * Replace the fiber optic and/or phototransistor.
21. Repeat steps 19 and 20 for the sector photocell. Connect the oscilloscope to the white leadwire terminal.
 22. Connect the oscilloscope external trigger to test point C of I028 Index pulse (C27) and set the External Sync switch to negative.
 23. Connect the oscilloscope probe to B14A (presector) and B14C (sector). The oscilloscope traces should meet the requirements of Figure 6-11.
 24. Connect 1X oscilloscope probes (to read differentially) to test points A and B of EUC card at X09 on the read/write logic chassis.
 25. Set the oscilloscope sweep frequency to 5 usec/cm.
 26. Set the power supply ACCESS MOTOR and DETENT circuit breakers to OFF.
 27. Manually pull the detent pawl, move the carriage to track 03, and allow the detent pawl to engage the detent gear.
 28. Set the maintenance panel OFF LINE/ON LINE switch to the OFF LINE READ 0 position.

29. Record the oscilloscope period between the Index pulse and the peak of the first data pulse (Figure 6-9).

NOTE

To read any head other than head 0 or 1, the selected head cable plug must be exchanged with either head 0 or head 1 at the head diode card. Connect heads 3, 4, 7, and 8 (Figure 6-7) at the head 0 head diode card connector. All other heads are exchanged with head 1. In either case, the maintenance panel OFF LINE/ON LINE switch must be positioned to reflect the exchange.

30. Repeat step 29 for the remaining heads.
31. The midpoint in the spread of the 10 recorded periods at track 03 must be approximately 20 usec. If this requirement is met, proceed to step 34.
32. If the requirement is not met, determine the difference between the actual midpoint and 20 and whether the actual midpoint must be increased or decreased.
33. Select one of the heads. Loosen the two bolts securing the sector/presector photocell mounting block to the disk drive main deck (Figure 6-10). Turn the mounting block adjusting screw under the solenoid arm clockwise to decrease or counterclockwise to increase the period. Stop adjusting when the period of the selected head has been changed by the amount and in the direction determined in step 32. Tighten the mounting block bolts and recheck the adjustment.
34. Press (to extinguish) the START switch. Remove the CE disk pack from the spindle.
35. Install the diode card at X10 on the read/write logic chassis.
36. Return the plug connections to the original configuration.
37. Remove the jumper wire from J102.

HOME CELL MECHANICAL ADJUSTMENT

1. Open and latch the disk drive top rear cover.
2. Remove the disk storage drive front panel.
3. Connect a jumper wire between pins R and U of connector J102.
4. Set the power supply circuit breakers to ON.
5. Connect the ground of an oscilloscope to the maintenance panel GROUND jack.
6. Connect the oscilloscope probe to the left leadwire terminal of the home cell phototransistor plate.

NOTE

The home cell may be considered saturated if the voltage drop across the photocell is less than 0.6 vdc.

7. Disengage the detent pawl and move the carriage to a position that results in maximum light on the home cell phototransistor. The oscilloscope should indicate a minimum of +4.5 vdc. Check the photocell supply voltage (black leadwire) and the output voltage. The photocell must be saturated.
8. Manually pull the detent pawl and position the carriage at track 00. The oscilloscope should indicate an output of -0.7 ± 0.2 vdc. Position the carriage at track -01. The output should be a minimum of +3 vdc. If these requirements are met, proceed to step 10.
9. If the requirements were not met, check the track indicator adjustment according to steps 10 and 11 of the Track Photocell Rotational Adjustment procedure. If this does not solve the problem, position the carriage at track 00 and loosen the two screws securing the notched mask (nearest to spindle) to the carriage. Position the mask, holding a clearance of approximately 1/16 inch between the mask and the mask of the phototransistor plate, until an output of -0.7 ± 0.2 vdc is attained. Tighten the screws securing the mask. Position the carriage at track -01. The output should be a minimum of +3 vdc. If this requirement is not met, replace the fiber optic and/or phototransistor.

10. Position the carriage at track 202. The oscilloscope should indicate an output of -0.7 ± 0.2 vdc. Position the carriage at track 203. The output should be a minimum of +3 vdc. If these requirements are met, proceed to step 12.
11. If the requirements were not met, position the carriage at track 202. Loosen the two screws securing the unnotched mask (farthest from the spindle) to the carriage. Position the mask, holding a clearance of approximately 1/16 inch between the mask and the mask of the photo-transistor plate until an output of -0.7 ± 0.2 vdc is attained. Tighten the screws securing the mask. Position the carriage at track 203. The output should be a minimum of +3 vdc. If this requirement is not met, replace the fiber optic and/or phototransistor.
12. Disconnect the oscilloscope. Remove the jumper wire at J102.

TRACK/SPEED PHOTOCCELL MECHANICAL ADJUSTMENT

1. Open and latch the disk storage drive top rear cover.
2. Remove the disk drive front panel.
3. Connect a jumper wire between pins R and U of connector J102.
4. Set the power supply MAIN POWER, DC INPUT POWER, and ± 20 vdc circuit breakers to ON.
5. Connect the ground of an oscilloscope to the maintenance panel GROUND jack. Connect the oscilloscope probe to the yellow leadwire terminal of the track phototransistor plate.
6. Manually pull the detent pawl and move the carriage back and forth. The photocell output trace should be an excursion between a low voltage of -0.6 ± 0.4 vdc and a high voltage of $+5.0 \pm 0.5$ vdc (Figure 6-12). The photocell must saturate (flat top) at the high voltage level as the carriage is moved back and forth. If the requirement is not met, unhook the pawl spring from the grooved pin. Slowly rotate the detent gear until the oscilloscope trace amplitude is maximum. If the photocell does not saturate, correct the situation according to one of the following:

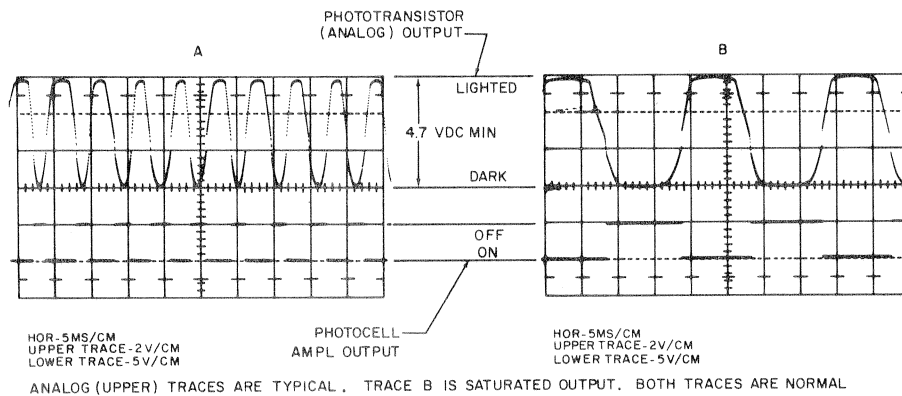

3042

Figure 6-12. Photocell/Amplifier Outputs

- Perform the Fiber Optic Adjustment procedure.
 - Loosen the two screws through the photocell clamps. Reposition the photocell radially for a maximum amplitude. Make certain that the photocell is sensing the correct row of slots on the timing disk. Tighten the clamp screws.
 - Refer to the Power Level Adjustment procedure. Adjust R03 until the cell saturates (do not exceed +6.0 vdc).
 - Replace the fiber optic and/or phototransistor.
7. If the screws in the photocell clamp were loosened in step 6, hook the pawl spring over the grooved pin and perform the Track Photocell Rotational Adjustment and the Actuator Dynamic Tests and Adjustments procedures.
 8. Connect the oscilloscope probe to the yellow leadwire terminal of the speed phototransistor plate. Repeat step 6.
 9. Hook the pawl spring over the grooved pin.
 10. Disconnect the oscilloscope.
 11. Remove the jumper wire at connector J102.

TRACK PHOTOCELL ROTATIONAL ADJUSTMENT

1. Open and latch the disk storage drive top rear cover.
2. Remove the disk storage drive front panel.
3. Connect a jumper wire between pins R and U of connector J102.
4. Set the power supply MAIN POWER, DC INPUT POWER, and ± 20 vdc circuit breakers to ON.
5. Connect the ground of an oscilloscope to the maintenance panel GROUND jack.
6. Connect the oscilloscope probe to the yellow leadwire terminal of the track phototransistor plate.
7. Disengage the detent pawl and move the carriage forward to approximately track 100. Allow the pawl tip to engage the detent gear between the teeth.
8. Loosen the three screws securing the photocell mounting plate (Figure 6-6) and slowly rotate the photocell mounting plate counterclockwise. Stop rotation when the oscilloscope trace reaches 0 vdc.
9. Tighten the three screws securing the photocell mounting plate. Make certain that the oscilloscope trace amplitude is still 0 vdc.
10. Disengage the detent pawl and position the carriage until the fiber optic light spot is located between the first two track slots clockwise from the blank area (interruption in slots), Figure 6-6. Release the detent pawl. The track indicator pointer should be pointing at 00 on the timing disk. Reposition the pointer as required.
11. Disengage the detent pawl and move the carriage out to the forward stop. The track indicator index should be 01 to 05 tracks beyond the last usable cylinder (0-199). If this requirement is not met, perform the Carriage Limit Stop Adjustment procedure.
12. If any adjustment was performed in step 8, perform the Actuator Dynamic Tests and Adjustments procedure.
13. Perform the Home Cell Mechanical Adjustment procedure.
14. Disconnect the oscilloscope and the jumper wire at J102.

CARRIAGE LIMIT STOP ADJUSTMENT

1. Open and latch the disk drive top rear cover.
2. Set the power supply MAIN POWER and DC INPUT POWER circuit breakers to OFF.
3. Disengage the detent pawl and move the carriage out to the forward stop. The track indicator index should be 01 to 05 tracks beyond the last usable cylinder (0-199). If this requirement is met, proceed to step 7.
4. If the requirement of step 3 is not met, remove the screws securing the head diode board. Under the diode board (and above the Delrin block, Figure 6-13) is a setscrew. Free the Delrin block by removing the screw immediately to the rear of this setscrew. Pull the Delrin block clear of the top edge of the carriage.
5. With the carriage against the forward stop, disengage the detent pawl and lift the front of the carriage slightly. Manually turn the detent gear until the track indication is 01 to 05 tracks beyond the last usable cylinder (0-199).
6. Lower the front end of the carriage, slide the Delrin block in place, and secure the rear screw. Secure the head diode board to the top of the actuator.
7. Disengage the detent pawl and position the carriage at approximately track 100. Using a feeler gage, check that the gap dimension between the bottom of the Delrin block and the top of the carriage (Figure 6-13) is between 0.001 and 0.004 inch.
8. If the requirement is not met, adjust the setscrew (located above Delrin block) to attain the correct dimension.
9. Disengage the detent pawl and check that the established dimension is maintained as the carriage is positioned at various tracks.
10. Disengage the detent pawl and extend the carriage until the cam follower just contacts the cam lug washer. The carriage stop bumper should be horizontal and just contacting the carriage mount below the home photocell assembly.

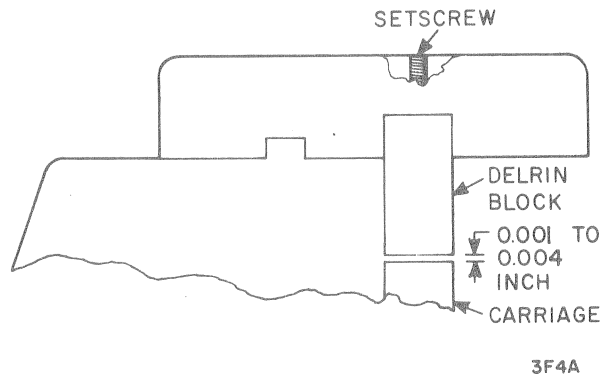

Figure 6-13. Carriage Limit Stop Adjustment

11. If the requirement of step 10 is not met, loosen the locking nut and adjust the stop. Tighten the locking nut.

HEAD LATCH SOLENOID AND SWITCH ADJUSTMENT

1. Open and latch the top rear cover.

NOTE

If the disk drive is disconnected from the controller, a jumper wire must be connected between pins R and U of connector J102.

2. Connect the disk drive power cords. Set all power supply circuit breakers, except ACCESS MOTOR and DETENT, to ON.
3. Install a disk pack. Pull upward on the rear cover interlock switch. Turn the Microswitch actuation adjust (Figure 6-14) counterclockwise until it is completely clear of the Microswitch actuating arm.
4. Press (to light) the START switch. The Unit indicator should not be lighted.
5. With the detent pawl disengaged from the detent gear, manually push the carriage forward while observing the head latch cam and arm. Stop moving the carriage as soon as the cam and arm become latched.
6. The disk drive Unit Number indicator should not be lighted. Adjust the Microswitch actuation adjust until the Unit Number indicator lights, and then turn the actuation adjust an additional three-quarters turn. Tighten the adjust setscrew locking nut.

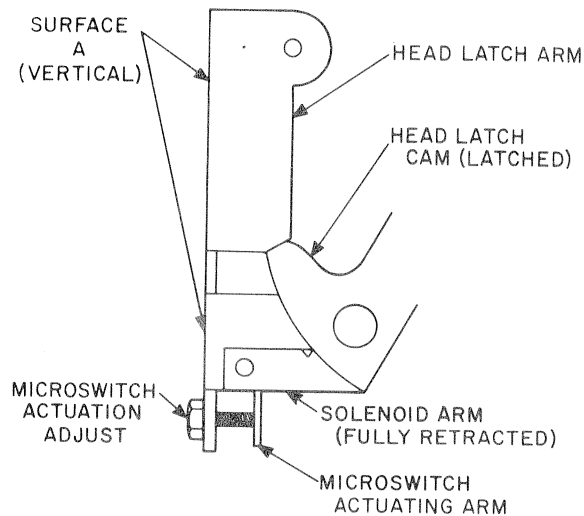

2R8

Figure 6-14. Head Latch Solenoid Adjustment

7. When the heads are latched, surface A (Figure 6-14) of the head latch arm must be vertical and the solenoid armature should be fully retracted. If this requirement is not met, loosen the two screws securing the solenoid to the bracket and reposition.
8. Remove the jumper wire at connector J102 (if used).

CAM LATCH SOLENOID ADJUSTMENT

1. Open and latch the disk drive top rear cover.
2. Set the power supply circuit breakers to ON.
3. Mount a disk pack on the spindle and tighten in place.
4. Pull upward on the rear cover interlock switch.
5. Press (to light) the START switch.
6. Set the ACCESS MOTOR and DETENT circuit breakers to OFF.
7. Manually disengage the detent pawl and move the carriage seven tracks forward.
8. Push the head loading cam forward until it locks in the upturned position.
9. Loosen the two screws securing the cam latch solenoid to the mounting bracket.

10. To prevent binding of the actuator arm, adjust the solenoid so that the actuator arm is parallel with the mounting bracket (Figure 6-15).
11. Tighten the two solenoid mounting screws.
12. Loosen the three screws securing the mounting bracket to the carriage mount assembly.

NOTE

The solenoid actuator arm must contact the cam latch collar with just enough tension so that the head loading cam (when energized) can be manually pulled back and when released will snap forward into the locked position.

13. Move the cam latch assembly until the solenoid actuator arm contacts the cam latch collar (Figure 6-15). Move the assembly forward so that the solenoid is slightly preloaded.
14. Tighten the three screws securing the solenoid mounting bracket to the carriage mount assembly.

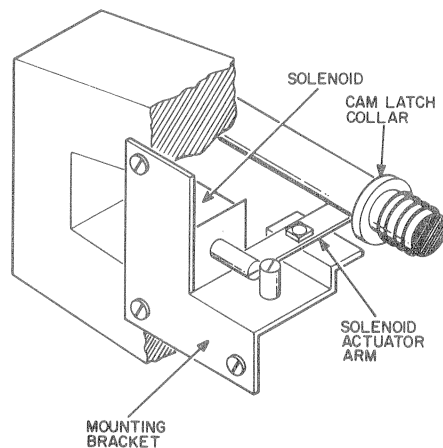

Figure 6-15. Cam Latch Solenoid Adjustment

COVER INTERLOCK SWITCHES ADJUSTMENT

1. Set the power supply MAIN POWER and DC INPUT POWER circuit breakers to OFF. Open and latch the top rear cover.
2. Adjust the top rear cover interlock switch as follows:
 - a. Connect an ohmmeter across the leadwire terminals of the rear cover interlock switch, S306 (located below and at rear of actuator).
 - b. Push the switch post down (to simulate top rear cover closed). The ohmmeter should indicate 0 ohm.
 - c. Allow the switch post to spring upward. The ohmmeter should indicate infinity. Disconnect the ohmmeter.
 - d. Lower the top rear cover while listening for the switch to close.
 - e. If the switch does not actuate when the cover is closed, loosen the screws in the switch mounting bracket and move the assembly upward. Repeat step d.
3. Adjust the front cover interlock switch as follows:
 - a. Connect an ohmmeter across the leadwire terminals of the front cover interlock switch, S304 (located on interior surface on actuator side of top rear cover).
 - b. Open and close the front cover while observing the ohmmeter indication.
 - c. The ohmmeter should indicate 0 ohm when the cover is closed and infinity when the cover is open. The switch should operate when a gap of 1.0 ± 0.5 inch exists between the front edge of the cover and the frame.
 - d. If the switch does not operate as required, loosen the two screws securing the switch and reposition it vertically.

ACTUATOR DYNAMIC TESTS AND ADJUSTMENTS

NOTE

In the following procedures, it is necessary to command the disk drive to perform various seek lengths. These commands may be derived from a disk storage drive exerciser or by using suitable software and the computer. Unit must meet requirements of Detent Adjustment and Delay Tests and Adjustments procedures before performing this procedure.

1. Open and latch the top rear cover of the disk drive.
2. Set the power supply circuit breakers ON.
3. Remove the front panel and connect the ground of an oscilloscope to the maintenance panel GROUND jack.
4. Install a disk pack. Pull upward on the rear cover interlock switch (behind carriage). Press (to light) the START switch.

CAUTION

A tachometer must be used when performing the following adjustments.

5. Attach a tachometer (84362900) to the access motor shaft.
6. Connect the oscilloscope external trigger to test point C of I218 Any Seek (C36). Connect the tachometer leadwires to the oscilloscope preamplifier input and preamplifier ground. Connect the tachometer leadwires so that a Forward Seek shows a positive envelope on the oscilloscope.
7. Command the disk storage drive to perform a 3-track repeat seek (three tracks forward and three tracks reverse, continuously) centering on track 100.

NOTE

The bottom traces shown on Figures 6-16 through 6-18 are provided for information only. They need not be displayed during the related procedure.

8. Set the oscilloscope vertical to 0.2 v/cm and the horizontal to 5 ms/cm. Compare the oscilloscope trace to Figure 6-16, Part A.

9. The average amplitude (Figure 6-16, part A) should be 0.040 vdc. Adjust the amplitude with the potentiometer on Y307 at logic chassis location B36 (counterclockwise adjustment increases the amplitude).
10. The start pulse applies high current to the access motor that causes acceleration from stop to 2 ips (Figure 6-16, part A, point A) in approximately 2 ms. The width of the start pulse is controlled by the potentiometer on Y315 at logic chassis location D37. Turn the potentiometer shaft clockwise until the oscilloscope trace overshoots Figure 6-16, part B, point A. Turn the potentiometer shaft counterclockwise until the overshoot disappears (Figure 6-16, part A). Figure 6-16, part C depicts an under-shoot condition.
11. The stop pulse applies high (reverse) current to the access motor that causes deceleration from 2 ips to 0 ips (Figure 6-16, part D, point B) in approximately 2 ms. The width of the stop pulse is controlled by the potentiometer on Y332 at logic chassis location D32. Adjust the pulse width as follows:
 - a. While the actuator performs the 3-track repeat seek, disengage and hold the detent pawl clear of the detent gear. Observe point B on the oscilloscope.
 - b. If point B is located above 0 vdc (Figure 6-16, part E) the stop pulse is too narrow. Turn the potentiometer shaft clockwise.
 - c. If point B is located below 0 vdc (Figure 6-16, part F), the stop pulse is too wide. Turn the potentiometer shaft counterclockwise.
12. The forward stop pulse delay is the time between the trailing edge of the last track pulse and the leading edge of the stop pulse during a Forward seek. This delay times the dropping of the detent pawl with respect to the detent gear position. Figure 6-17 shows the tachometer output trace for a properly adjusted delay (point A is where the pawl should engage the gear and area A is the resulting carriage rebound caused by engagement). The pawl should not engage the gear before zero velocity is reached. The amplitude and duration of TA is primarily a function of the accuracy of the detent gear and the timing disk assembly. It is therefore necessary to inspect the operation at a minimum of three positions (approximately

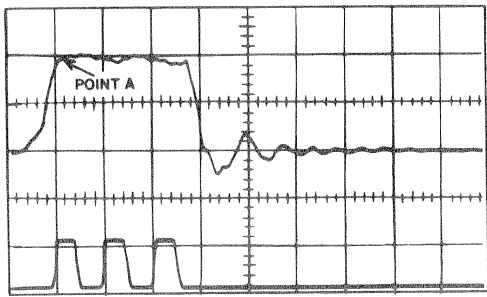

A NORMAL

TOP-TACHOMETER
HOR-5MS/CM VERT-0.2V/CM
BOTTOM-TRACK PHOTOCELL
HOR-5MS/CM VERT-5V/CM

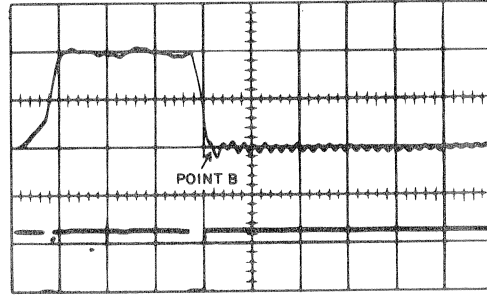

D NORMAL

TOP-TACHOMETER
HOR-5MS/CM VERT-0.2V/CM
BOTTOM-START/STOP PULSE (A42A)
HOR-5MS/CM VERT-0.5V/CM

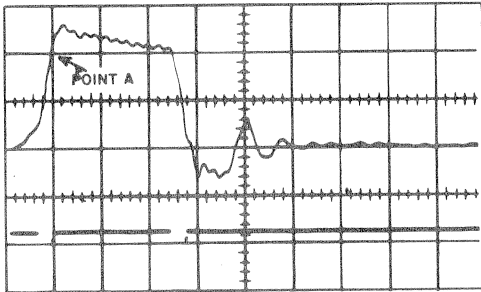

B START PULSE-
WIDTH TOO LONG

TOP-TACHOMETER
HOR-5MS/CM VERT-0.2V/CM
BOTTOM-START/STOP PULSE (A42A)
HOR-5MS/CM VERT-0.5V/CM

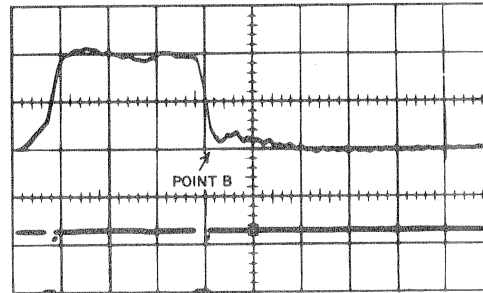

E STOP PULSE-
WIDTH TOO SHORT

TOP-TACHOMETER
HOR-5MS/CM VERT-0.2V/CM
BOTTOM-START/STOP PULSE (A42A)
HOR-5MS/CM VERT-0.5V/CM

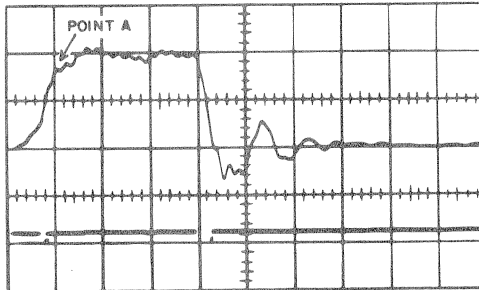

C START PULSE-
WIDTH TOO SHORT

TOP-TACHOMETER
HOR-5MS/CM VERT-0.2V/CM
BOTTOM-START/STOP PULSE (A42A)
HOR-5MS/CM VERT-0.5V/CM

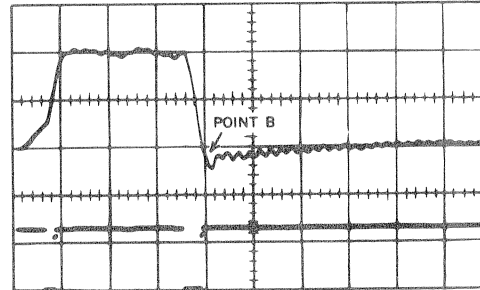

F STOP PULSE-
WIDTH TOO LONG

TOP-TACHOMETER
HOR-5MS/CM VERT-0.2V/CM
BOTTOM-START/STOP PULSE (A42A)
HOR-5MS/CM VERT-0.5V/CM

3T13

Figure 6-16. Tachometer Output (3-Track Forward Seek)

tracks 09, 100, and 189).

NOTE

Make certain that the oscilloscope displays the tachometer output resulting from the forward portion of the repeat seek.

- a. While the actuator performs a 3-track repeat seek centering on Track 100, observe the resulting trace.
- b. Adjust Y331 (D33) to make the trace approximate Figure 6-17, if required.
- c. The width of TA should be 5 ± 3 ms.
- d. Position the carriage to Track 09 and 189. At each position command a 3-track repeat seek and repeat step c.
- e. If the optimum (Figure 6-17) tachometer output cannot be achieved, perform the procedures of step 14.

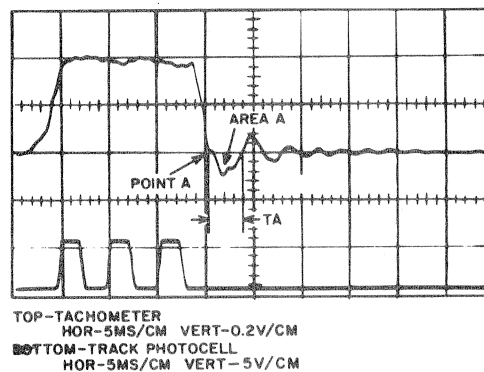

Figure 6-17. Tachometer Output (Forward Seek)

13. The reverse stop pulse delay is the time between the trailing edge of the last track pulse and the leading edge of the stop pulse during a Reverse Seek. This delay times the dropping of the detent pawl with respect to the detent gear position. Figure 6-18 shows the tachometer output trace for a properly adjusted delay (area B is the rebound caused by the pawl/gear engagement). The pawl should not engage the gear before zero

velocity is reached. The amplitude and duration of TB is primarily a function of the accuracy of the detent gear and timing disk assembly. It is therefore necessary to inspect the operation at a minimum of three positions (approximately tracks 09, 100 and 189).

NOTE

Make certain that the oscilloscope displays the tachometer output resulting from the reverse portion of the repeat seek.

- a. Connect the oscilloscope external trigger to test point C of K214 Reverse FF (C28). While the actuator performs a 3-track seek centering on Track 100, compare the trace to Figure 6-18.
- b. Adjust Y330 (D34) to make the trace approximate Figure 6-18, if required.
- c. The width of TB should be 2 (+3, -2) ms.
- d. Position the carriage to track 09 and 189. At each position command a 3-track repeat seek and repeat step c.
- e. Recheck step 12 and then proceed to step 14.

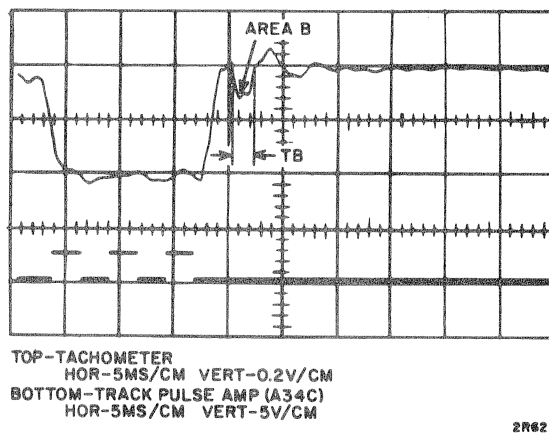

Figure 6-18. Tachometer Output (Reverse Seek)

14. Perform the dynamic test and adjustment of the track photocell as follows:
 - a. Command the disk storage drive to perform a 3-track repeat seek centering on track 100.
 - b. Monitor the tachometer output on one channel of the oscilloscope. Connect the other channel to the yellow leadwire terminal of the track phototransistor plate.
 - c. Refer to Figure 6-19, part A, for oscilloscope settings. Each of the track pulses should swing between a low voltage of -0.6 ± 0.4 vdc and a high voltage of $+5.0 \pm 0.5$ vdc. There should be no track pulses of less amplitude during the settle time (as shown by FAULT on Figure 6-19, part A). If the extra pulses do exist, they will be corrected during the following steps.
 - d. If the amplitude of the track pulses is less than +4.7 vdc, adjust the track photocell according to the Track/Speed Photocell Mechanical Adjustment procedure.
 - e. Disconnect the oscilloscope probe at the track photocell and connect it to the track pulse amplifier, test point C at logic chassis location A34.
 - f. Connect the oscilloscope external trigger to test point C of I218 Any Seek (C36). Command the disk storage drive to perform a 1-track repeat seek (one track forward and one track reverse, continuously) at track 100.
 - g. Refer to Figure 6-19, part B, for oscilloscope settings and compare waveforms. The track pulses should be approximately coincidental (leading and trailing edges of pulse vertically aligned).
 - h. Slightly loosen the three screws securing the photocell mounting plate, Figure 6-6.

- i. As the unit performs the 1-track repeat seek, observe the pair of track pulses on the oscilloscope. If the forward pulse is to the left of the reverse pulse, very lightly tap the photocell mounting plate downward. If the forward pulse is to the right of the reverse pulse, place a screwdriver between the main deck and the bottom of the photocell mounting plate and force the plate upward.
- j. When the oscilloscope trace is similar to Figure 6-19, part B, tighten the three locking screws in the photocell mounting plate. Make certain that the trace does not change.
- k. Disconnect the oscilloscope (except the ground connection).
- l. Moving the photocell mounting plate changed the reference of the forward and reverse stop pulse delays. Repeat steps 12 and 13. If the forward or reverse delay cannot be made short enough (pawl engages gear before zero velocity is reached) in steps 12 or 13, the photocell mounting block may be repositioned to favor the direction in which the difficulty occurs.
- m. Perform the Home Cell Mechanical Adjustment procedure.

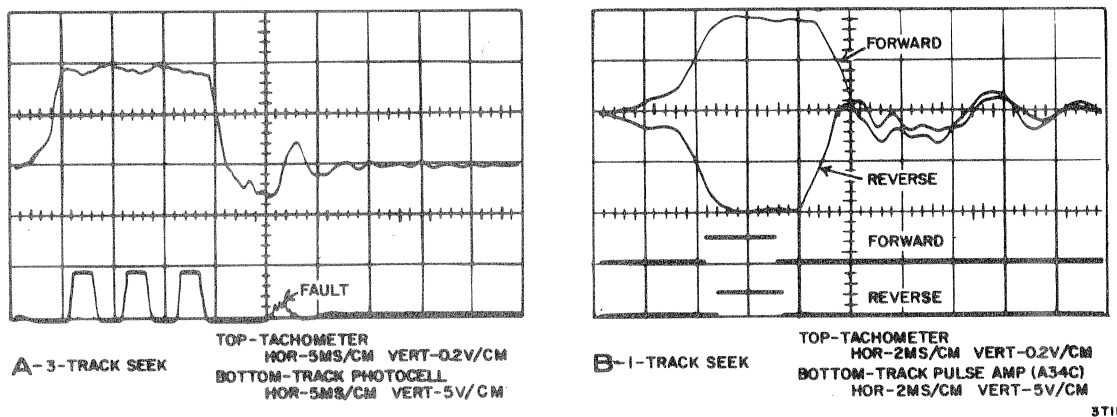

Figure 6-19. Dynamic Track Photocell Adjustment

15. Perform the seek profile tests and adjustments as follows:
 - a. Connect the oscilloscope external trigger to test point C of I218 Any Seek (C36). Monitor the tachometer output on one channel of the oscilloscope. Connect the other channel to the track pulse amplifier at test point C of logic chassis location A34.
 - b. Command the disk storage drive to perform a 4-track repeat seek (four tracks forward and four tracks reverse continuously) centering at Track 100. Refer to Figure 6-20, part A for oscilloscope settings and the required trace. If required, adjust the potentiometer shaft at B43 (Y313) until there is a sharp drop from the higher velocity to the 2 ips plateau without any overshoot at point A.
 - c. Command the disk storage drive to perform a 16-track repeat seek centering at track 100. Refer to Figure 6-20, part B for oscilloscope settings and the required trace. If required, adjust the potentiometer shaft at B35 (Y306) so that the 6 ips plateau amplitude is approximately 1.2 volts and the 2 ips plateau occurs before the next to last track pulse.

NOTE

If the 6 ips plateau is not flat, repeat step 13. If the track pulse timing is difficult to read due to signal instability, lower the 6 ips speed slightly and it will settle down.

- d. Command the disk storage drive to perform a 64-track repeat seek centering at track 100. Refer to Figure 6-20, part C for oscilloscope settings and the required trace. If required, adjust the potentiometer shaft at B34 (Y305) so that the 15 ips plateau amplitude is approximately 3 volts and the period of the 6 ips plateau is 6 ± 2 ms.
- e. Command the disk storage drive to perform a 128-track repeat seek centering at track 100. Refer to Figure 6-20, part D for oscilloscope settings and the required trace. If required, perform the following adjustments.
 - Adjust the 6 ips plateau (shaft at B35) to a position that ensures the start of the 2 ips plateau by the end of the next to last track pulse.

- Adjust the 15 ips plateau (shaft at B34) to a position that causes the 6 ips plateau to have a period of $6 \pm \text{ms}$.
- f. Command the disk storage drive to perform a 202-track repeat seek. Refer to Figure 6-20, part E for oscilloscope settings and the required trace. The duration of the 15 ips plateau should be 5 ms minimum. The duration of the 15 ips plateau is controlled by changing its amplitude. Raising the amplitude lengthens the duration. If the 5 ms minimum duration is not met, readjust the 6 ips and 15 ips plateaus as described in step e (with the actuator performing a 202-track repeat seek).

READ OPERATION TEST AND ADJUSTMENT

1. Open and latch the top rear cover of the disk storage drive.

NOTE

The following procedure requires that data be written on a disk pack. The Write operation may be done via a disk storage driver exerciser or the central processor. Timing measurements of the recorded data require that the oscilloscope be triggered from an external source that is synchronous with the data being displayed. Oscilloscope synchronizing with the Index pulse or internally on the signal results in signal instability that may make measurements unreliable. If a disk storage drive exerciser is used, a suitable sync point is available at exerciser test point D, location A04. Amplitude measurements can be made with the oscilloscope triggered by Index test point C, logic chassis location C27.

2. Remove the disk storage drive rear panel. Set the power supply circuit breakers to ON. Mount a disk pack (not a CE disk pack) on the spindle and tighten in place.
3. Pull the post of the interlock switch (behind carriage) upward. Press (to light) the START switch.

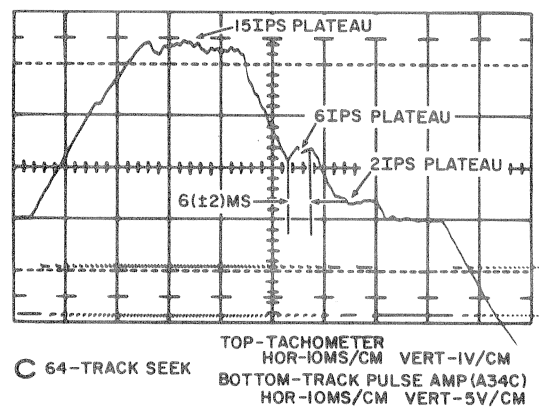
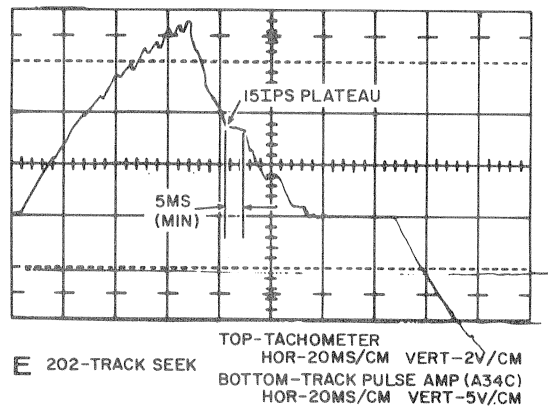
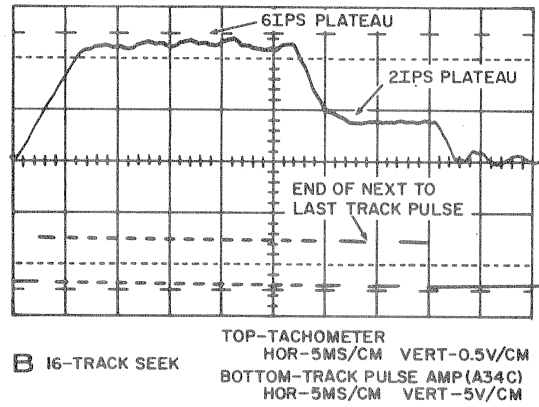
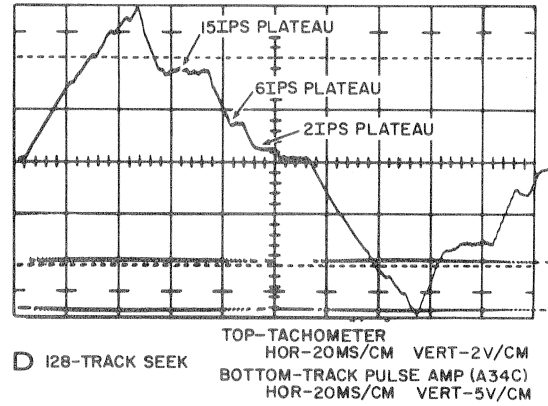
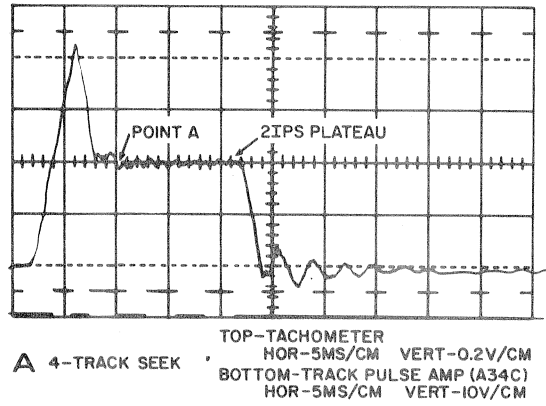

2R67B

Figure 6-20. Tachometer Output (Various Seek Lengths)

4. Test and adjust the ATB/ATC card adjustment as follows:
 - a. Write a pattern of all "1's" with each head at track 202.
 - b. Ground an oscilloscope at the maintenance panel GROUND jack. Connect the external trigger according to the above note. Connect the oscilloscope differentially to test points A and B of the EUC card at X09 (read/write logic chassis).
 - c. Select any head and read track 202. Make oscilloscope settings according to Figure 6-24, part C.
 - d. Turn the potentiometer shaft on the ATB/ATC card at X12 (read/write logic chassis) clockwise until the amplitude of the trace is maximum, then turn the shaft three turns counterclockwise. The amplitude of the signal (Figure 6-24, part C) will be a minimum of 0.6 volt.

5. Test and adjust the EWC card adjustment as follows:
 - a. Write a pattern of all "1's" with each head at Track 202.
 - b. Ground an oscilloscope at the maintenance panel GROUND jack. Connect the external trigger according to the above note. Connect the oscilloscope probe to test point C of L402 (A01).
 - c. Select any head and read Track 202. Make oscilloscope settings and a trace comparison according to Figure 6-21.
 - d. The pulses should be 200 ± 50 nsec wide and should occur every 400 nsec. Adjust the pulse symmetry with the potentiometer shaft at A02, if required.
 - e. Select several heads. There should be no measurable difference in the symmetry of the traces for any of the heads.

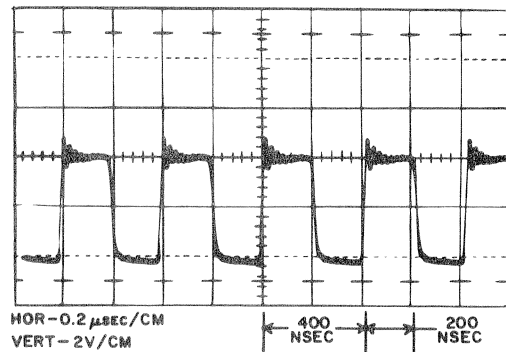

Figure 6-21. Pulse Shaper Trace

6. Test the read/write head peak shift as follows:
 - a. Write a pattern of alternate "1's" and "0's" with each head at Track 202.
 - b. Ground an oscilloscope at the maintenance panel GROUND jack. Connect the external trigger according to the above note. Connect the oscilloscope probe to test point C of L402 (A01).
 - c. Select any head and read track 202. Make oscilloscope settings and a trace comparison according to Figure 6-22, parts A and B. The trace should meet the requirements of Figure 6-22, part B.
 - d. Repeat step c for the remaining read/write heads.
 - e. If the requirements of Figure 6-22 are not met, replace the applicable head/arm assembly and/or the related torsion arm assembly.

7. Test the read/write head amplitude as follows:
 - a. Ground an oscilloscope at the maintenance panel GROUND jack. Connect the external trigger according to the above note. Connect the oscilloscope differentially to test points A and B of the EUC card at X09 (read/write logic chassis).
 - b. Refer to Figures 6-23 and 6-24. Write the pattern of "1's" or "0's" on the specified track with all heads. Read the data from each head and compare it with the applicable figure. The figures depict typical amplitudes that will be encountered. A pattern of all "1's" at track 202 (Figure 6-24, parts A and C) should result in a minimum amplitude of approximately 1 volt, although amplitudes of slightly less are acceptable if no readback problems have been encountered.

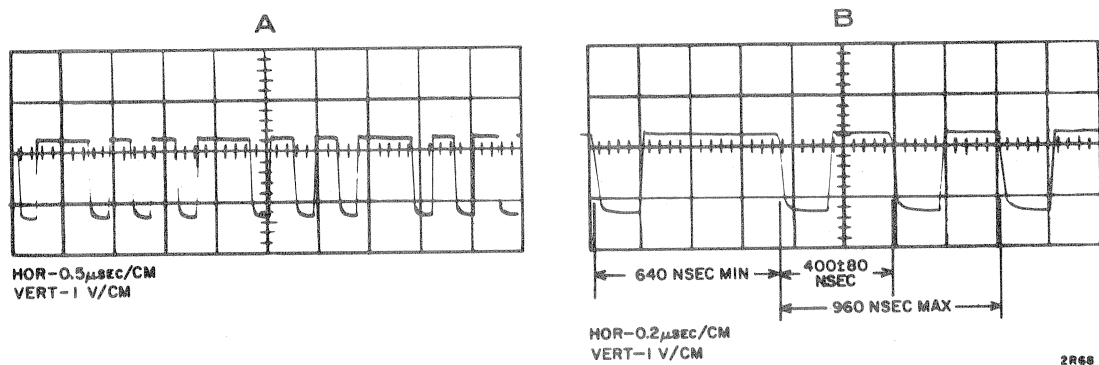
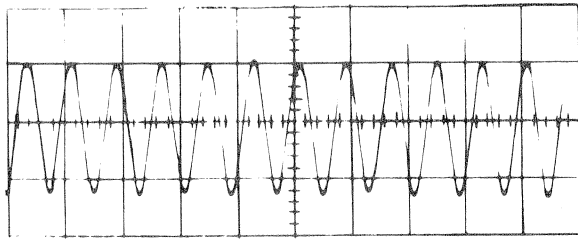
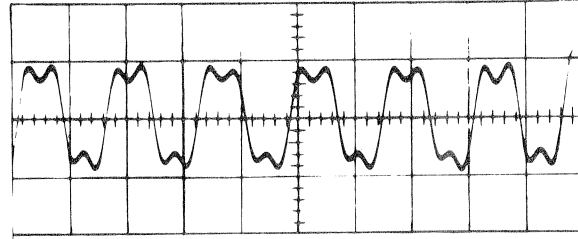

Figure 6-22. Read/Write Peak Shift



A-TRACK 00 ALL "1's" HOR-1 μ SEC/CM VERT-1V/CM



B-TRACK 00 ALL "0's" HOR-1 μ SEC/CM VERT-1V/CM

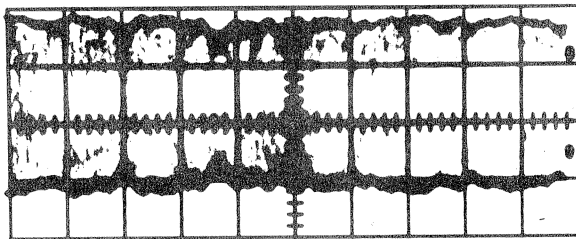

C-TRACK 00 ALL "1's" HOR-2MS/CM VERT-1V/CM

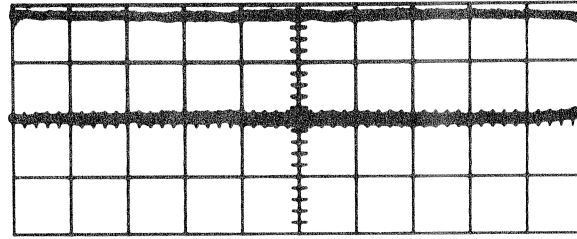

D-TRACK 00 ALL "0's" HOR-2MS/CM VERT-1V/CM

2W10

Figure 6-23. Read/Write Amplitude (Track 00)

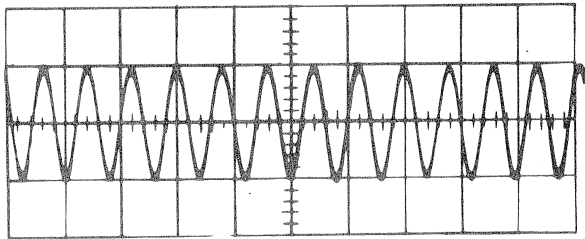

A-TRACK 202 ALL "1's" HOR-1 μ SEC/CM VERT-0.5V/CM

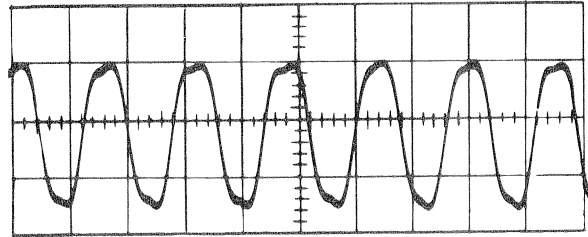

B-TRACK 202 ALL "0's" HOR-1 μ SEC/CM VERT-0.5V/CM

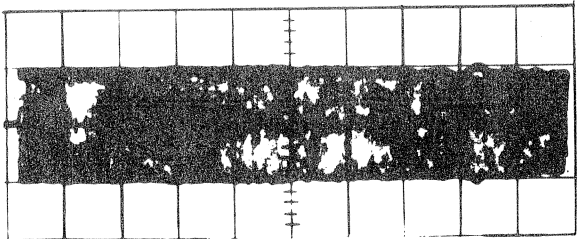

C-TRACK 202 ALL "1's" HOR-2MS/CM VERT-0.5V/CM

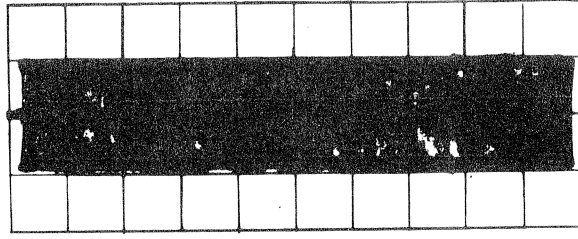

D-TRACK 202 ALL "0's" HOR-2MS/CM VERT-0.5V/CM

2W11

Figure 6-24. Read/Write Amplitude (Track 202)

DELAY TESTS AND ADJUSTMENTS

The procedures of this paragraph cover the following delays: Y203 and Y221 (On Cylinder), Y312, and Y407 (Head Select).

NOTE

In the following procedures, it is necessary to command the disk storage drive to perform Seek operations. These commands may be derived from a disk storage drive exerciser or the central processor.

1. Remove the disk storage drive rear panel and set the power supply circuit breakers to ON.
2. Install a disk pack. Press (to light) the START switch.
3. Remove the disk storage drive front panel. Ground an oscilloscope at the maintenance panel GROUND jack.
4. Adjust delays Y203 and Y221 as follows:
 - a. Connect the oscilloscope external trigger and channel A probe to test point C of I220 (B28). Set the External Sync switch to positive.
 - b. Connect the channel B probe to test point A of Y203 (A30).
 - c. Command the disk storage drive to perform a 1-track repeat seek operation.
 - d. Make oscilloscope settings and trace comparisons according to Figure 6-25, part A. Adjust the potentiometer shaft on Y203 until its Output pulse is delayed by 10 ms with respect to the "0" output of I220.
 - e. Connect the oscilloscope external trigger and channel A probe to test point A of Y203 (A30).
 - f. Connect the channel B probe to test point A of Y221 (A36).
 - g. Make oscilloscope settings and trace comparisons according to Figure 6-25, part B. Adjust the potentiometer shaft on Y221 until its Output pulse is delayed by 200 usec with respect to the "0" output of Y203.
 - h. Stop the Seek operation.

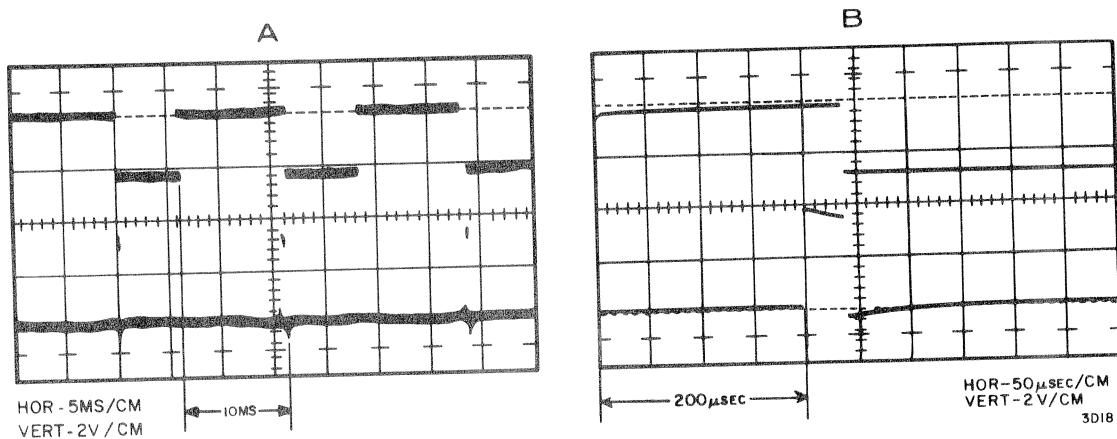

Figure 6-25. On Cylinder Delay Timing

5. Adjust delay Y312 as follows:
 - a. Connect the oscilloscope external trigger and channel A probe to test point C of K213 Detent FF (C38). Set the External Sync switch to positive.
 - b. Connect the channel B probe to test point C of Y312 (B42).
 - c. Set the oscilloscope horizontal sensitivity to 0.5 ms/cm. Command the disk storage drive to perform a 1-track repeat seek.
 - d. Observe the delay time of Y312. Slowly turn the potentiometer shaft counterclockwise. Note the duration of the delay when the detent fails to pick.
 - e. Turn the shaft a few turns clockwise and restart the disk storage drive. Continue to turn the shaft clockwise until the delay time is 0.5 ms greater than the delay noted in step d or equals 2 ms.
 - f. If the final delay time (step e) is not the same as the initial delay time (step d), perform the Actuator Dynamic Tests and Adjustments procedure.

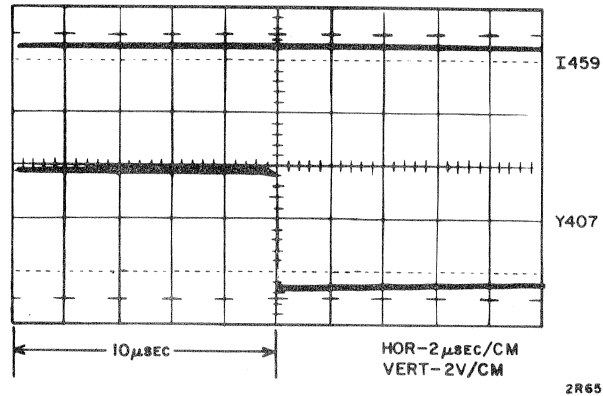

Figure 6-26. Head Select Timing

6. Adjust delay Y407 as follows:

NOTE

During the following procedure, it is necessary that a Control Select signal be received by the disk storage drive once each revolution of the disk pack. If an exerciser is being used, this requirement is met automatically. If the central processor is controlling the unit, suitable software must cause this occurrence.

- a. Connect the oscilloscope external trigger and channel A probe to test point D of I459 (D21).
 - b. Connect the channel B probe to test point C of Y407 (D09).
 - c. Make oscilloscope settings and trace comparisons according to Figure 6-26. As the 1-track repeat cycles, adjust the potentiometer shaft of Y407 until its output pulse is delayed by 10 μ sec with respect to the "0" output of I459.
7. Disconnect the oscilloscope.

POWER LEVEL ADJUSTMENT

1. Remove the disk storage drive rear panel.

NOTE

If the disk drive is disconnected from the controller, a jumper wire must be connected between pins R and U of connector J102.

2. Set the DC INPUT, MAIN POWER, AND ± 20 vdc circuit breakers to ON.

WARNING

Dangerous voltages are present in the power supply. When making power supply adjustments, do not contact interior components other than those to be adjusted.

3. Using a multimeter, make voltage checks and adjustments as follows:

NOTE

Voltage measurements made at the read/write logic chassis necessitate opening the disk drive top rear cover. When this is done, power is removed unless the cover Interlock switch behind the carriage is pulled upward.

- a. Measure +20 (+1, -0) vdc at read/write logic chassis locations X22-15 and -14 (ground). Unlatch power supply panel and adjust rheostat R03 if required.
- b. Measure -20 (-1, +0) vdc at read/write logic chassis locations X22-13 and -14 (ground). Unlatch power supply panel and adjust rheostat R04 as required.

NOTE

In the following step R03 is a part of the auxiliary power supply located on the disk storage drive directly below the main power supply chassis.

- c. Measure $+5.7 \pm 0.2$ vdc at the power supply LAMP and DC GRD jacks. Adjust R03 in the auxiliary power supply if required.

POWER SUPPLY TROUBLESHOOTING PROCEDURE

External test equipment connections to the power supply are made to test points on the front panel of the unit (located behind the lower rear panel). The terminals are labeled for easy reference.

Troubleshooting of the individual portions of the power supply requires that the front panel be lowered. If the power supply must be opened, observe the following warning.

WARNING

Make certain that the power supply is not connected to any power source, and that all capacitors have been discharged before making any external connections.

Initially troubleshoot the power supply by checking the following:

1. Using a multimeter, note the output voltage and ripple at the front panel test points.
2. Check the line voltage applied to the power supply.
3. Visually inspect the power supply for burned or damaged parts, foreign matter, and loose leads.

WARNING

The power supply is capable of producing voltages that are dangerous. Whenever measurements are being made on internal components, be sure that the measuring equipment case has a common ground with the power supply. Whenever test equipment leads are attached or removed, the power supply should be turned off.

The troubleshooting chart (Table 6-1) lists the symptom, probable cause, and remedy. To properly check the power supply and associated circuits, match the observed symptom with the symptom on the chart, then complete the analysis and correction.

CAUTION

Before making any continuity measurement, remove all input power.

TABLE 6-1. TROUBLESHOOTING CHART

SYMPTOM	PROBABLE CAUSE	REMEDY
1. Phase indicator lamp does not illuminate	<ul style="list-style-type: none"> a. No input power b. MAIN POWER circuit breaker defective c. Defective wiring d. Lamp defective 	<p>Check to assure that the main power cable is connected.</p> <p>With the main power cable disconnected, check the continuity of the circuit breaker.</p> <p>Check the continuity of the neutral and phase wiring from input connector J01 to output connector J04.</p> <p>Check, by replacement, the continuity of the lamp.</p>
2. Phase lamp illuminates but fans do not operate	<ul style="list-style-type: none"> a. Defective wiring 	<p>Check continuity of fans (the wiring between the input and TB05-1, and the wiring between the input and TB05-2).</p>
3. Phase lamp illuminates, power supply fans operate, but logic chassis fans do not operate	<ul style="list-style-type: none"> a. Defective wiring 	<p>Check the continuity between the input wiring and pin 1 of J05. Check the continuity between the input wiring and pin 3 of J05. Make the necessary corrections.</p>
4. No voltage at +20 test point	<ul style="list-style-type: none"> a. Loss of input voltage b. Rectifier diode defective c. Capacitor C03 shorted d. Resistor R03 defective e. Choke L02 open 	<p>Check voltage at pins 8 and 9 of ferroresonant transformer T01.</p> <p>Check continuity of rectifier diodes CR04A and CR04B.</p> <p>Check the continuity of the component using a multi-meter set to the Rx1 meg scale.</p> <p>Check resistance of the resistor.</p> <p>Check continuity of the choke.</p>

TABLE 6-1. TROUBLESHOOTING CHART (Cont'd)

SYMPTOM	PROBABLE CAUSE	REMEDY
	<ul style="list-style-type: none"> f. Contacts 3C and 3A of K02 are pitted g. Capacitor C04 shorted 	<p>Check continuity of the relay contacts. Replace K02 if necessary.</p> <p>Check C04 using a multi-meter set to the Rx1 meg scale.</p>
<p>5. Improper voltage at +20 test point</p>	<ul style="list-style-type: none"> a. R03 needs adjustment b. Leaky or open output filter c. Capacitor C03 open or leaky d. CR13 shorted e. Improper front-to-back ratio on rectifier diodes CR04A and CR04B f. Bleeder resistor R02 open 	<p>Adjust R03 for the proper output.</p> <p>Check C04 using a multi-meter set to the Rx1 meg scale</p> <p>Check C03 using a multi-meter set to the Rx1 meg scale.</p> <p>Check reverse resistance of CR13 on the Rx100 scale.</p> <p>Check and replace if defective</p> <p>Check resistance and replace if necessary.</p>
<p>6. Excessive ripple at +20 test point</p>	<ul style="list-style-type: none"> a. Leaky or open output filter b. Shorted turns of choke c. Improper front-to-back ratio on rectifier diodes CR04A and CR04B 	<p>Check C04 using a multi-meter set to the Rx1 meg scale.</p> <p>Check and replace L02 if defective.</p> <p>Check and replace if defective.</p>
<p>7. No voltage at -20 test</p>	<ul style="list-style-type: none"> a. Loss of input voltage b. Rectifier diode defective 	<p>Check voltage at pins 8 and 9 of ferroresonant transformer T01.</p> <p>Check continuity of rectifier diodes CR01A and CR02A.</p>

TABLE 6-1. TROUBLESHOOTING CHART (Cont'd)

SYMPTOM	PROBABLE CAUSE	REMEDY
	<ul style="list-style-type: none"> c. Capacitor C01 shorted d. Resistor R04 defective e. Choke L01 open f. Contacts 4C and 4A of K02 are pitted g. Capacitor C02 is shorted 	<p>Check C01 using a multi-meter set to the Rx1 meg scale.</p> <p>Check resistance of resistor.</p> <p>Check continuity of choke.</p> <p>Check continuity of the relay contacts and replace K02 if necessary.</p> <p>Check C02 using a multi-meter set to the Rx1 meg scale.</p>
<p>8. Improper voltage at -20 test point</p>	<ul style="list-style-type: none"> a. R04 needs adjustment b. Leaky or open output filter c. Capacitor C01 open or leaky d. Diode CR14 is shorted e. Improper front-to-back ratio on rectifier diodes CR01A and CR02A f. Bleeder resistor R01 open 	<p>Adjust R04 for the proper output.</p> <p>Check C02 using a multi-meter set to the Rx1 meg scale.</p> <p>Check C01 using a multi-meter set to the Rx1 meg scale.</p> <p>Check reverse resistance of CR14 on the Rx100 scale.</p> <p>Check and replace if defective</p> <p>Check the resistance and replace if necessary.</p>
<p>9. Excessive ripple at -20 test point</p>	<ul style="list-style-type: none"> a. Leaky or open output filter b. Shorted turns of filter choke c. Improper front-to-back ratio on rectifier diodes CR01A and CR02A 	<p>Check C02 using a multi-meter set to the Rx1 meg scale.</p> <p>Check and replace L01 if defective.</p> <p>Check and replace if defective.</p>

TABLE 6-1. TROUBLESHOOTING CHART (Cont'd)

SYMPTOM	PROBABLE CAUSE	REMEDY
10. No voltage at +20Y test point	<ul style="list-style-type: none"> a. Capacitor C09, C10, or C11 shorted b. Bad lead or broken solder connection 	<p>Check the capacitors using a multimeter set to the Rx1 meg scale.</p> <p>Check continuity, isolate and repair the defective lead.</p>
11. Improper voltage at +20Y test point	<ul style="list-style-type: none"> a. Leaky or open capacitor b. Resistor R06 is open 	<p>Check the capacitors using a multimeter set to the Rx1 meg scale.</p> <p>Check and replace if defective.</p>
12. Excessive ripple at +20Y test point	<ul style="list-style-type: none"> a. Leaky or open capacitor b. Improper front-to-back ratio on rectifier diodes CR01B and CR02B 	<p>Check the capacitors using a multimeter set to the Rx1 meg scale.</p> <p>Check and replace if defective</p>
13. No voltage at +40 test point	<ul style="list-style-type: none"> a. No input power b. Transformer T02 is defective c. Capacitor C07 is shorted d. Contacts of CB05 are not making contact e. Contacts 2 and 8 of K05B are not making electrical contact f. Rectifier CR03A or B is shorted 	<p>Check the continuity from pins 8 and 9 of T01 to pins 1 and 2 of T02 respectively.</p> <p>Check the voltage developed across pins 3 and 5 of T02. Replace the transformer if defective.</p> <p>Check the capacitor using a multimeter set to the Rx1 meg scale.</p> <p>Check continuity and replace if necessary.</p> <p>Check and replace K05 if defective.</p> <p>Check the reverse resistance of the diodes using a multimeter set to the Rx1 meg scale.</p>

TABLE 6-1. TROUBLESHOOTING CHART (Cont'd)

SYMPTOM	PROBABLE CAUSE	REMEDY
14. Improper voltage at +40	<ul style="list-style-type: none"> a. One half of the transformer is shorted or open b. Rectifier CR03A or B is defective c. Capacitor C07 is leaky d. Resistor R09 is defective. e. Bad lead or broken solder connection 	<p>Check continuity and re- place if necessary.</p> <p>Check the forward and reverse resistance using a multimeter set to the Rx1 meg scale.</p> <p>Check and replace if necessary.</p> <p>Check continuity and resis- tance of the resistor.</p> <p>Check continuity, isolate, and repair the defective lead.</p>
15. Excessive ripple at +40 test point	<ul style="list-style-type: none"> a. Leaky or open capacitor b. Rectifier CR03A or B is defective 	<p>Check C07 and replace if defective</p> <p>Check the forward and reverse resistance using a multimeter set to the Rx1 meg scale.</p>
16. No automatic First Seek	<ul style="list-style-type: none"> a. H switch failure circuit b. Bad lead or solder connect- ion c. Detent pawl not pulled d. Detent pawl pulled, then dropped, prior to loading heads 	<p>With the disk drive in the on condition and the START switch ON, check the base bias of the forward trans- istors and check the applied supply voltages. Repair the defect.</p> <p>Check continuity, isolate, and repair the defective lead.</p> <p>Check Q07 and associated circuit. Replace if defective.</p> <p>Check transistor Q01 and associated circuit. Replace defective part.</p>
17. Heads are loaded but no reverse drive	<ul style="list-style-type: none"> a. Reverse drive transistors Q05 or Q04 are defective 	<p>Check transistors and re- place if defective.</p>

TABLE 6-1. TROUBLESHOOTING CHART (Cont'd)

SYMPTOM	PROBABLE CAUSE	REMEDY
	b. Bad lead or solder connection	Check continuity of H switch reverse drive section, isolate, and repair the defect.
18. Brake solenoid not operating	a. Shunt diode is shorted b. Relay contacts not completing circuit or defective lead or solder connection. c. Pawl binding	Check reverse resistance of CR05 using a multimeter set to Rx100 scale. Check continuity, isolate, and repair defect. Check adjustment according to Section 6.
19. Sequence power is not completed to successive units	a. Bad lead or broken solder connection or defective relay	Check continuity of circuit, isolate, and repair defective lead or replace defective relay.

SECTION 7

SPECIAL MAINTENANCE INFORMATION

SPECIAL MAINTENANCE INFORMATION

This section contains information required at the time of initial installation and setup.

INSTALLATION REQUIREMENTS AND PROCEDURES

The installation of the disk storage drive equipment requires only that allowance be made for the physical space requirements of the machine. These requirements are the height, width, depth, and weight of the machine plus 3 additional feet in front of and to the rear of the machine. This additional space is needed to allow for proper maintenance of the machine.

Figure 7-1 illustrates the outline dimensions of the equipment.

For an initial installation, the packing material should be removed and the disk storage drive carefully taken from the container. Inspection for shipping damage should then be made. All claims for damage should be filed promptly with the transportation company involved. If claims are filed for shipping damage, save the original packing case and materials.

INITIAL CHECKOUT PROCEDURE

NOTE

Machine adjustments should be made only if the unit is not operating properly. Adjustments may drift outside of the tolerances provided. Such drift should not in itself be cause for adjustment.

The following procedures and visual inspections should be performed at the site immediately following installation and before the disk storage drive is placed in operation. If the equipment does not respond as outlined, corrective procedures must be performed.

1. Open the plexiglass cover over the spindle assembly and remove and discard the plastic spindle cover.
2. Grasp and turn the spindle. The spindle should rotate with little resistance. Wipe the spindle surface clean using an alcohol-dampened gauze.
3. Close the plexiglass cover.
4. Remove the lower rear cabinet panel to expose the power supply.
5. Place all circuit breakers in the OFF position. Inspect the intracabling connections of the unit (Figure 7-2).

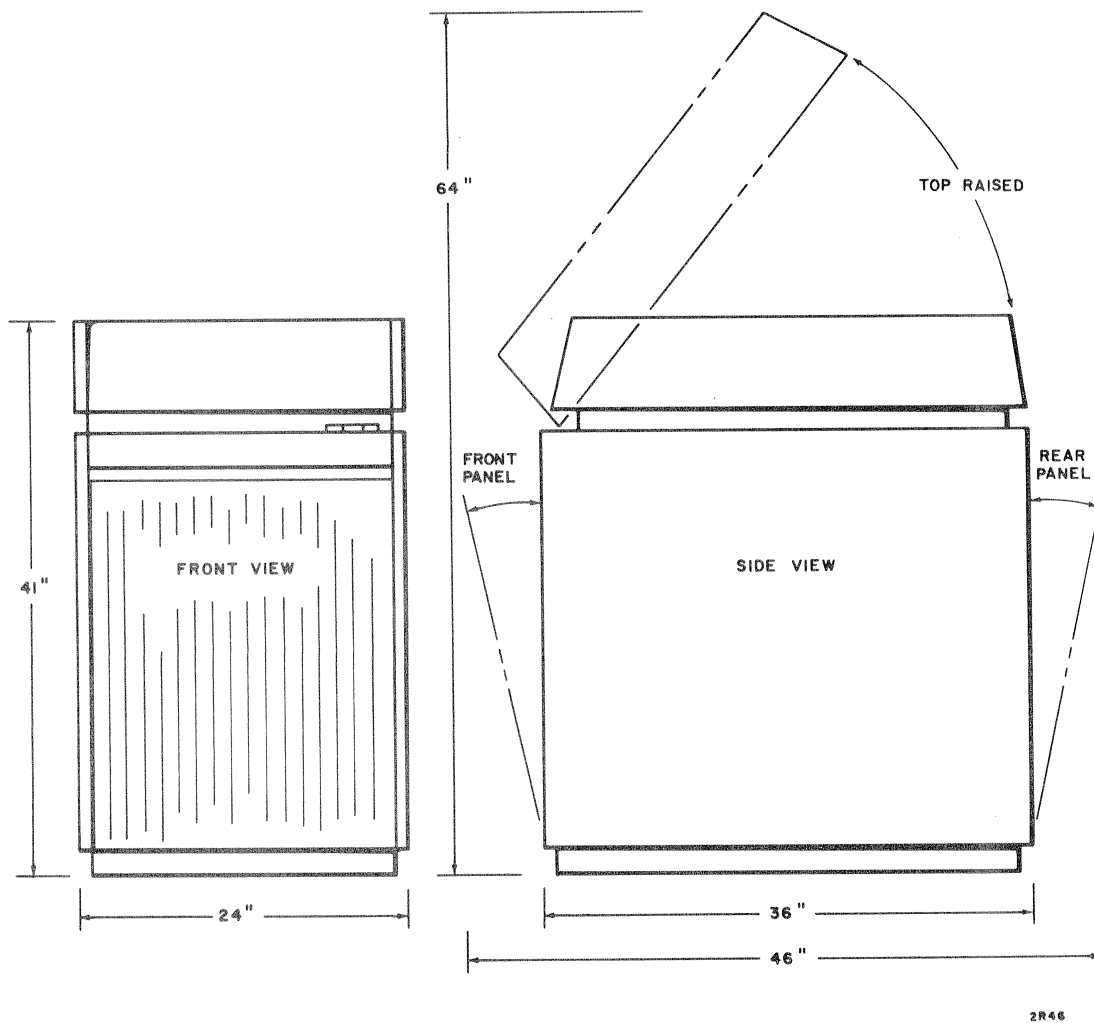

Figure 7-1. Outline Dimensions

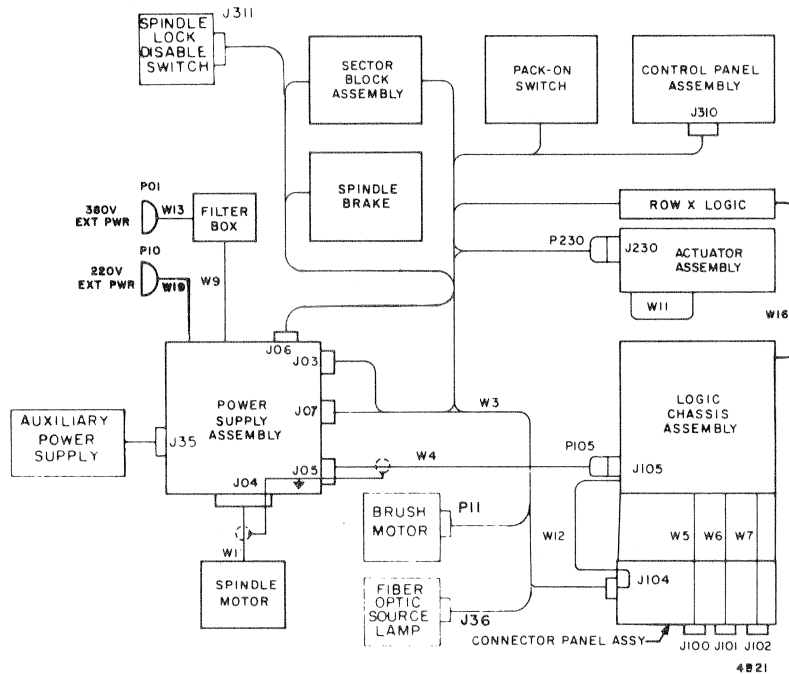

Figure 7-2. Intracabling of Disk Storage Drive

6. Open and latch the disk drive top rear cover. Inspect the remaining intracabling connections of the unit (Figure 7-2).
7. Close the top rear cover.
8. Slip the primary power cables through the cable entry port in the base of the drive unit. Connect the plugs to the proper power sources, as shown in the equipment specifications.
9. Place the MAIN POWER and DC input power circuit breakers in the ON position. The phase indicator lamps should light and the blowers in the power supply and the logic chassis should start.
10. Place the remaining power supply circuit breakers in the ON position. The related indicators should light.
11. Install the lower rear cabinet panel.
12. Mount a disk pack on the spindle assembly as described in Section 2.

NOTE

The disk pack must rotate counterclockwise. If the disk pack rotates clockwise, the facility wiring of the receptacle is incorrect. Reverse the connection of any 2-phase leadwires of that receptacle.

13. Press (to light) the START switch on the operator control panel.
 - a. START indicator lights.
 - b. Disk pack is brought up to speed.
 - c. Brush assembly completes clean cycle of disk pack.
 - d. Actuator performs a First seek.

DISK PACK RUNOUT CHECK

This procedure determines whether a bent disk pack may remain in use. If the disk pack fails to meet the requirements of the procedure, it should be returned to the manufacturer for reconditioning.

1. Open and latch the disk drive top rear cover.
2. Remove the four screws and washers securing the plastic shroud. Set the shroud aside.
3. Install the disk pack to be checked on the spindle.
4. Place the disk pack runout gage (84357600) on the disk drive base plate (Figure 7-3).
5. Turn the bezel of the dial indicator to indicate zero. Orient the dial indicator so that the plastic tip is not only contacting the disk surface but is deflected for an indication of approximately 0.020 inch. Tighten the dial indicator in this position. Turn the bezel to zero the indicator.
6. Manually and slowly rotate the disk pack one full revolution while carefully observing the dial indicator. The sum of the deviations (to either side of zero) should not exceed 0.012 inch.
7. If a total deflection of 0.012 inch is encountered in step 6, recheck the indication. The total deflection must occur in a disk circumference of 4 inches or more.

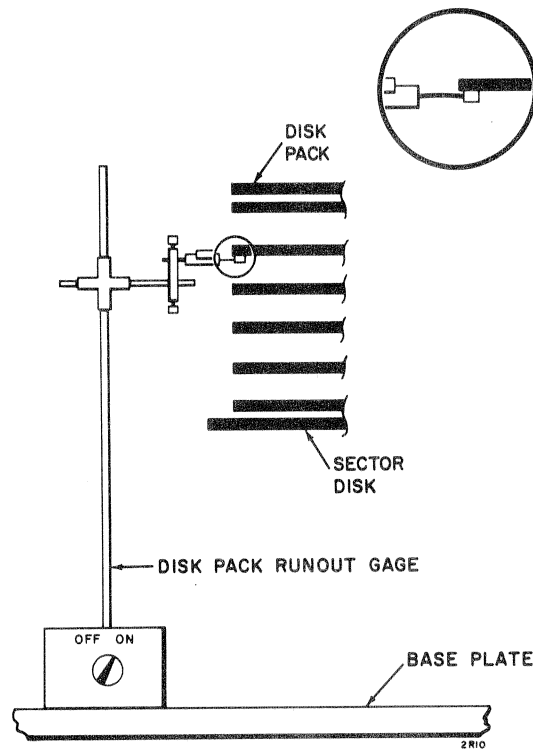

Figure 7-3. Disk Pack Runout Gage

8. Repeat steps 5 through 7 for the eight remaining disk surfaces.
9. Remove the disk pack and the disk pack runout gage.
10. Install the shroud with four screws and washers. Make certain the carriage, sector/presector block, and the brush assembly fit properly through the openings in the shroud. Pull the shroud toward the front of the unit to ensure that it protects the heads when the carriage is in the retracted position.

COMMENT SHEET

MANUAL TITLE 9465 DISK STORAGE DRIVE, Maintenance

PUBLICATION NO. 41247200 REVISION B

FROM: NAME: _____
BUSINESS
ADDRESS: _____

COMMENTS:

This form is not intended to be used as an order blank. Your evaluation of this manual will be welcomed by Control Data Corporation. Any errors, suggested additions or deletions, or general comments may be made below. Please include page number references and fill in publication revision level as shown by the last entry on the Record of Revision page at the front of the manual. Customer engineers are urged to use the TAR.

CUT ALONG LINE

PRINTED IN U.S.A.

AA 3419

NO POSTAGE STAMP NECESSARY IF MAILED IN U. S. A.

FOLD ON DOTTED LINES AND STAPLE

STAPLE

STAPLE

FOLD

FOLD

FIRST CLASS
PERMIT NO. 8241
MINNEAPOLIS, MINN.

BUSINESS REPLY MAIL
NO POSTAGE STAMP NECESSARY IF MAILED IN U.S.A.

POSTAGE WILL BE PAID BY
CONTROL DATA CORPORATION
8100 34TH AVENUE SOUTH
MINNEAPOLIS, MINNESOTA 55440

ATTN: TECHNICAL PUBLICATIONS DEPT.
PLANT TWO

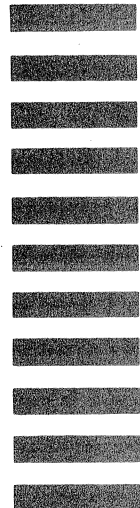

CUT ALONG LINE

FOLD

FOLD



LITHO IN U.S.A.

8100 34th AVE. SO., MINNEAPOLIS, MINN. 55440

CONTROL DATA
CORPORATION

>>> CUT OUT FOR USE AS LOOSE-LEAF BINDER TITLE TAB

